



ANSI/IEEE Std 315A-1986
(Supplement to ANSI Y32.2-1975,
ANSI/IEEE Std 315-1975)

adopted by the
**DEPARTMENT
OF DEFENSE**
United States of America

see inside front cover
for acceptance notice

American National Standard
IEEE Standard

**Supplement to
Graphic Symbols for
Electrical and Electronics
Diagrams**

Published by
The Institute of Electrical and Electronics Engineers, Inc
345 East 47th Street, New York, NY 10017, USA

ANSI/IEEE Std 315A-1986
24 December, 1986
(Supplement to
ANSI Y32.2-1975,
ANSI/IEEE Std 315-1975)

Acceptance Notice

This non-Government standard was adopted on 24 December, 1986, and is approved for use by the DoD. The indicated industry group has furnished the clearance required by existing regulations. Copies of the document are stocked by DoD Single Stock Point, Naval Publications and Forms Center, Philadelphia, PA 19120, for issue to DoD activities only. Contractors and industry groups must obtain copies directly from the Institute of Electrical and Electronics Engineers, Inc, 345 East 47th Street, New York, NY 10017.

Title of Document: IEEE Standard
Supplement to Graphic Symbols for Electrical and Electronics Diagrams

Document No: ANSI/IEEE Std 315A-1986

Date of Specific Issue Adopted: 12 September, 1986

Releasing Industry Group: The Institute of Electrical and Electronics Engineers, Inc

Custodians:
Army — AR
Navy — SH
Air Force — 16

Military Coordinating Activity:
Army — AR
Project DRPR-0285

Review Activities:
Army — AV, ER, CR
Navy — AS, OS, YD

User Activities:
Army — ME, MI
Navy — EC, MC

NOTICE: When reaffirmation, amendment, revision, or cancellation of this standard is proposed, the industry group responsible for this standard shall inform the military coordinating activity of the requested change and request participation.

**American National Standard
IEEE Standard**

**Supplement to
Graphic Symbols for
Electrical and Electronics Diagrams**

Sponsor
**IEEE Standards Coordinating Committee 11, Graphic Symbols
Institute of Electrical and Electronics Engineers**

Approved September 19, 1985
Institute of Electrical and Electronics Engineers

Approved November 15, 1985
American National Standards Institute

© Copyright 1986 by

**The Institute of Electrical and Electronics Engineers, Inc
345 East 47th Street, New York, NY 10017, USA**

*No part of this publication may be reproduced in any form,
in an electronic retrieval system or otherwise,
without the prior written permission of the publisher.*

IEEE Standards documents are developed within the Technical Committees of the IEEE Societies and the Standards Coordinating Committees of the IEEE Standards Board. Members of the committees serve voluntarily and without compensation. They are not necessarily members of the Institute. The standards developed within IEEE represent a consensus of the broad expertise on the subject within the Institute as well as those activities outside of IEEE which have expressed an interest in participating in the development of the standard.

Use of an IEEE Standard is wholly voluntary. The existence of an IEEE Standard does not imply that there are no other ways to produce, test, measure, purchase, market, or provide other goods and services related to the scope of the IEEE Standard. Furthermore, the viewpoint expressed at the time a standard is approved and issued is subject to change brought about through developments in the state of the art and comments received from users of the standard. Every IEEE Standard is subjected to review at least once every five years for revision or reaffirmation. When a document is more than five years old, and has not been reaffirmed, it is reasonable to conclude that its contents, although still of some value, do not wholly reflect the present state of the art. Users are cautioned to check to determine that they have the latest edition of any IEEE Standard.

Comments for revision of IEEE Standards are welcome from any interested party, regardless of membership affiliation with IEEE. Suggestions for changes in documents should be in the form of a proposed change of text, together with appropriate supporting comments.

Interpretations: Occasionally questions may arise regarding the meaning of portions of standards as they relate to specific applications. When the need for interpretations is brought to the attention of IEEE, the Institute will initiate action to prepare appropriate responses. Since IEEE Standards represent a consensus of all concerned interests, it is important to ensure that any interpretation has also received the concurrence of a balance of interests. For this reason IEEE and the members of its technical committees are not able to provide an instant response to interpretation requests except in those cases where the matter has previously received formal consideration.

Comments on standards and requests for interpretations should be addressed to:

Secretary, IEEE Standards Board
345 East 47th Street
New York, NY 10017
USA

The individual symbols contained in this standard may be copied, reproduced, or employed in any fashion without permission of the IEEE. Any statement that the symbols used are in conformance with this standard shall be on the user's own responsibility.

Foreword

(This Foreword is not a part of ANSI/IEEE Std 315A-1986, Supplement to Graphic Symbols for Electrical and Electronics Diagrams.)

This standard supplements ANSI/IEEE Std 315-1975 by providing symbols approved by the International Electrotechnical Commission since 1975, or for which there is now a greater need in the United States arising from international commerce. It is believed that immediate issue of this supplement is preferable to the inevitable delay that would occur if a complete and proper revision of ANSI/IEEE Std 315-1975 were undertaken.

Besides adding new symbols, some updating of the information in ANSI/IEEE Std 315-1975 has been undertaken. The updating includes references to other standards, IEC labels on symbols where a change has occurred, and correction of errors.

This supplement is based on IEC Publication 617, Parts 2 through 11 and Part 13 as published in 1983. IEC Publication 617, Part 12 is included in full in ANSI/IEEE Std 91-1984, IEEE Standard Graphic Symbols for Logic Functions.

When this standard was approved SCC 11.1 had the following membership:

C. J. Andrasco	G. A. Knapp	H. H. Seaman
I. M. Berger	J. M. Kreher	G. Shapiro
L. Burns	F. R. Misiewicz	J. W. Siefert
R. Coel	C. R. Muller	S. V. Soanes
J. B. Deam	C. McCarthy	R. M. Stern
L. Davis	R. Pinger	M. E. Taylor
A. C. Gannett	A. I. Rubin	R. J. Yuhas
	L. Schulz	

When this standard was approved the IEEE Standards Coordinating Committee on Letter and Graphic Symbols, SCC 11, had the following membership:

Robert B. Angus, Jr	Conrad R. Muller	S. V. Soanes
J. C. Brown	John B. Peatman	Roger M. Stern
John M. Carroll	J. William Siefert	Leter H. Warren
Gordon A. Knapp	Thomas R. Smith	Steven A. Wasserman

When the IEEE Standards Board approved this standard on September 19, 1985, it had the following membership:

John E. May, *Chairman*

John P. Riganati, *Vice Chairman*

Sava I. Sherr, *Secretary*

James H. Beall	Jay Forster	Lawrence V. McCall
Fletcher J. Buckley	Daniel L. Goldberg	Donald T. Michael*
Rene Castenschild	Kenneth D. Hendrix	Frank L. Rose
Edward Chelotti	Irvin N. Howell	Clifford O. Swanson
Edward J. Cohen	Jack Kinn	J. Richard Weger
Paul G. Cummings	Joseph L. Koepfinger*	W. B. Wilkens
Donald C. Fleckenstein	Irving Kolodny	Charles J. Wylie
	R. F. Lawrence	

*Member emeritus

Second Printing
February 1989

Contents

SECTION	PAGE	SECTION	PAGE
AA1 Purpose	7	4.36 Block Symbols for Motor Starters	20
AA2 Scope	7	4.37 Operating Devices for Electromechanical (all or nothing) Relays	20
AA3 Organization	7		
AA4 References	7		
Section 1 Qualifying Symbols		Section 5 Graphic Symbols for Terminals and Connectors	
1.1 Adjustability Variability	9	5.3 Connector Disconnecting Device Jack Plug	22
1.2 Special-Property Indicators	9	5.6 Coaxial Connector Coaxial Junction	22
1.3 Radiation Indicators (electromagnetic and particulate)	9		
1.4 Physical-State Recognition Symbols	9		
1.7 Direction of Flow of Power, Signal, or Information	9		
1.8 Kind of Current	10		
1.10 Envelope Enclosure	10		
1.14 Operational Dependence On a Characteristic Quantity	10		
1.15 Signal Identifiers	10		
1.16 Signal Waveforms	10		
1.17 Control by Nonelectrical Quantities	10		
Section 2 Graphic Symbols for Fundamental Items (not included in other sections)		Section 6 Graphic Symbols for Transformers, Inductors, and Windings	
2.1 Resistor	11	6.1 Core	23
2.2 Capacitor	11	6.2 Inductor Winding Reactor Radio-Frequency Coil Telephone Retardation Coil	23
2.3 Antenna	11	6.4 Transformer Telephone Induction Coil Telephone Repeating Coil	23
2.4 Attenuator	12	6.6 Ferrite Cores — Symbol Elements	26
2.6 Delay Function Delay Line Slow-Wave Structure	12	6.7 Ferrite Cores	27
2.9 Pickup Head	12	6.8 Magnetic Storage Matrices (Topographical Representation)	27
2.10 Piezoelectric Crystal Unit	12		
2.17 Igniter Plug	13		
2.18 Ideal Circuit Elements	13		
2.19 Faults	13		
Section 3 Graphic Symbols for Transmission Path		Section 7 Graphic Symbols for Electron Tubes and Related Devices	
3.1 Transmission Path Conductor Cable Wiring	13	7.1 Electron Tube	28
3.2 Distribution Lines Transmission Lines	14	7.3 Typical Applications	29
3.6 Waveguide	14	7.4 Solion Ion-Diffusion Device	29
3.10 Pressure Tight Bulkhead Cable Gland Cable Sealing End	14	7.5 Coulomb Accumulator Electrochemical Step-Function Device.	29
		7.7 Nuclear-Radiation Detector Ionization Chamber Proportional Counter Tube Geiger-Müller County Tube	30
Section 4 Graphic Symbols for Contacts, Switches, Contactors, and Relays			
4.1 Switching Function	15		
4.3 Basic Contact Assemblies	15		
4.6 Switch	17		
4.14 Limit Switch Sensitive Switch	17		
4.21 Thermostat	17		
4.22 Flasher Self-Interrupting Switch	17		
4.29 Contactor	17		
4.34 Multipole and Multiposition Switches	18		
4.35 Switchgear and Controlgear	20		
		Section 8 Graphic Symbols for Semi- conductor Devices	
		8.2 Element Symbols	31
		8.3 Special-Property Indicators	31
		8.5 Typical Applications, Two-Terminal Devices	32
		8.6 Typical Applications, Three- (or more) Terminal Devices	33
		8.10 Photon-Coupled Isolator	35
		8.12 Ionizing Radiation Detectors	35
		Section 9 Graphic Symbols for Circuit Protectors	
		9.1 Fuse	36
		9.3 Lightning Arrester Arrester (electric surge) Gap	36
		9.4 Circuit Breaker	36
		9.6 Protective Relays — Block Symbols and Qualifying Symbol	37
		9.7 Examples of Protective Relays	37
		9.8 Other Relay Devices	38

SECTION	PAGE	SECTION	PAGE
Section 10 Graphic Symbols for Acoustic Devices		Section 16 Graphic Symbols for Composite Assemblies	
10.1 Audible-Signaling Device	39	16.1 Circuit Assembly Circuit Subassembly Circuit Element	49
Section 11 Graphic Symbols for Lamps and Visual-Signaling Devices		16.2 Amplifier	49
11.1 Lamp	39	16.9 Gyro Gyroscope Gyrocompass	49
11.3 Electromechanical Signal	39	16.13 Changer, General Symbol — Converter General Symbol	49
Section 12 Graphic Symbols for Readout Devices		16.14 Galvanic Separator	49
12.1 Meter Instrument	40	16.15 Heat Source, General Symbol	49
12.2 Electromagnetically Operated Counter Message Register	40	16.16 Generator, General Symbol	49
12.3 Indicating, Recording, and Integrating Instruments, General Symbols	40	16.17 Sensors and Detectors	50
12.4 Examples of Indicating Instruments	40	16.18 Applications of Sensors	50
12.5 Examples of Recording Instruments	41	Section 17 Graphic Symbols for Analog and Digital Logic Functions	
12.6 Examples of Integrating Instruments	41	17.10 Analog Elements for Computations and Control	51
12.7 Counting Devices	41	Section 18 Graphic Symbols for Digital Logic Functions	
12.8 Telemetry Devices	42	No changes	
12.9 Electric Clocks	42	Section 19 Graphic Symbols for Special-Purpose Maintenance Diagrams	
Section 13 Graphic Symbols for Rotating Machinery		No changes	
13.1 Rotating Machine	42	Section 20 Graphic Symbols Commonly Used on System Diagrams, Maps, and Charts (Communications Equipment)	
13.5 Applications: Alternating-Current Machines	42	20.3 Exchange Equipment (Relocation of 20.3.2 and 20.3.3)	53
13.6 Applications: Alternating-Current Machines with Direct-Current Field Excitation	42	Section 21 Graphic Symbols Commonly Used on System Diagrams, Maps, and Charts	
Section 14 Graphic Symbols for Mechanical Functions		21.1 Generating Station	54
14.2 Mechanical Motion	43	21.2 Hydroelectric Generating Station	54
14.3 Clutch Brake	43	21.3 Thermoelectric Generating Station	54
14.4 Manual Control	43	21.4 Prime Mover	54
14.5 Detents, Latching, and Blocking	44	21.5 Substation	54
Section 15 Graphic Symbols Commonly Used in Connection with VHF, UHF, and SHF Circuits		21.6 Wind Generating Station	54
15.2 Coupling	45	21.7 Plasma Generating Station	54
15.4 Hybrid Directionally Selective Transmission Devices	45	Section 22 Class Designation Letter	
15.5 Mode Transducer	45	No changes	
15.6 Mode Suppressor	45	Section 23 Referenced Standards	
15.7 Rotary Joint	45	See AA4	7
15.8 Nonreciprocal Devices	45	Section 24 Telecommunications Switching and Peripheral Equipment	
15.9 Resonator Tuned Cavity	45	24.1 Switching Systems	55
15.10 Resonator (Cavity-Type) Tube	45	24.2 Block Symbols for Switching Equipment	57
15.11 Magnetron	46	24.3 Qualifying Symbols for Transducers, Recorders, and Reproducers	57
15.12 Velocity-Modulation (Velocity- Variation) Tube	46	24.4 Recorders and Reproducers	57
15.13 Transmit-Receive (TR) Tube	46		
15.14 Traveling-Wave-Tube	47		
15.16 Filter	48		
15.20 Multiport Devices	48		
15.21 Lasers and Masers	48		

SECTION	PAGE	SECTION	PAGE
Section 25 Telecommunications			
Transmission			
25.1	Amplified Circuits58	25.7	Electronic Chopping Device59
25.2	Qualifying Symbols for Pulse Modulation58	25.8	Threshold Devices59
25.3	Signal Generator, Waveform Generator58	25.9	Terminating Sets60
25.4	Changers, Converter, General Symbol58	25.10	Modulator, Demodulator, Discriminator60
25.5	Filters59	25.11	Concentrators, Multiplexers60
25.6	Networks59	25.12	Frequency Spectrum Diagram Symbol Elements61
		25.13	Examples of Frequency Spectrum Diagrams61
		25.14	Fiber Optic Devices62

American National Standard IEEE Standard

Supplement to Graphic Symbols for Electrical and Electronics Diagrams

AA1. Purpose

This supplement is intended to provide additional graphic symbols and information on internationally approved graphic symbols needed for use for electrical and electronics diagrams.

AA2. Scope

This supplement provides graphic symbols for use on all electrical or electronics diagrams except for those required for

(1) Logic circuit diagrams. See ANSI/IEEE Std 91-1984 [4]¹.

(2) Architectural plans. See ANSI Y32.9-1972 [2] and IEC Publication 617 (1983) [22] Part 11, ch IV.

(3) Street maps and building system layouts for cable TV application. See ANSI/IEEE Std 623-1976 [8] and IEC Publication 617 (1983) [22], Part 11, ch III.

AA3. Organization

This supplement places the IEC Publication 617 new material in a practical sequence with related material in ANSI/IEEE Std 315-1975 [7]. Except where the nature of the revisions dictate otherwise (for reasons of clarity) existing ANSI/IEEE Std 315-1975 [7] text is not repeated.

¹Numbers in brackets correspond to those of the references listed in Section AA4.

AA4. References

This standard shall be used in conjunction with the following publications:

[1] ANSI Y1.1-1972 (R 1984), Abbreviations for Use On Drawings and In Text.²

[2] ANSI Y32.9-1972, American National Standard Graphic Symbols for Electrical Wiring and Layout Diagrams Used in Architecture and Building Construction.

[3] ANSI/IEEE Std C37.2-1979, IEEE Standard Electrical Power System Device Function Numbers.³

[4] ANSI/IEEE Std 91-1984, IEEE Standard Graphic Symbols for Logic Functions.

[5] ANSI/IEEE Std 260-1978, IEEE Standard Letter Symbols for Units of Measurement.

[6] ANSI/IEEE Std 280-1985, IEEE Standard Letter Symbols for Quantities Used in Electrical Science and Electrical Engineering.

[7] ANSI/IEEE Std 315-1975, Graphic Symbols for Electrical and Electronics Diagrams.

[8] ANSI/IEEE Std 623-1976, Graphic Symbols for Grid and Mapping Diagrams Used in Cable Television Systems.

²ANSI publications are available from the Sales Department, American National Standards Institute, 1430 Broadway, New York, NY 10018.

³IEEE publications are available from IEEE Service Center, 445 Hoes Lane, Piscataway, NJ 08854.

[9] IEC Publication 27-1 (1971) Part 1: General. Letter Symbols to be Used in Electrical Technology.⁴

[10] IEC Publication 417 (1973), Graphic Symbols for Use on Equipment.

[11] IEC Publication 445 (1973), Identification of Apparatus Terminals and General Rules for a Uniform System of Terminal Marking, Using an Alphanumeric Notation.

[12] IEC Publication 617-1 (1985) Part 1: General Information, General Index. Cross-Reference Tables.

[13] IEC Publication 617-2 (1983) Part 2: Symbol Elements, Qualifying Symbols and Other Symbols Having General Application.

[14] IEC Publication 617-3 (1983) Part 3: Conductors and Connecting Devices.

[15] IEC Publication 617-4 (1983) Part 4: Passive Components.

[16] IEC Publication 617-5 (1983) Part 5: Semiconductors and Electron Tubes.

[17] IEC Publication 617-6 (1983) Part 6: Production and Conversion of Electrical Energy.

[18] IEC Publication 617-7 (1983) Part 7: Switchgear, Controlgear, and Protective Devices.

[19] IEC Publication 617-8 (1983) Part 8: Measuring Instruments, Lamps, and Signaling Devices.

[20] IEC Publication 617-9 (1983) Part 9: Telecommunications: Switching and Peripheral Equipment.

[21] IEC Publication 617-10 (1983) Part 10: Telecommunications: Transmission.

[22] IEC Publication 617-11 (1983) Part 11: Architectural and Topographical Installation Plans and Diagrams.

[23] IEC Publication 617-12 (1983) Part 12: Binary Logic Elements.

[24] IEC Publication 617-13 (1978) Part 13: Analog Elements.

[25] ISO 31, Parts 0-11 (1974-1980), Quantities, Units, Symbols, Conversion Factors, and Conversion Tables.⁵

⁴IEC Publications are available in the United States from the Sales Department, American National Standards Institute, 1430 Broadway, New York, NY 10018, USA. The IEC publications are also available from International Electrotechnical Commission, 3, rue de varembe, Case postale 131, CH 1211—Geneva 20, Switzerland.

⁵ISO publications are available in the United States from the Sales Department, American National Standards Institute, 1430 Broadway, New York, NY 10018, USA. ISO publications are also available from the International Organization for Standardization, 1, rue de Varembe, Case postale 56, CH 1211, Geneva 20, Switzerland.

Qualifying Symbols

1.1.1.2 Preset, general

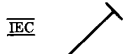

Add:

Information on the conditions under which adjustment is permitted may be shown near the symbol.

1.1.1.2.1 Application: preset adjustment permitted only at zero current.



After 1.1.4.2

Add:

1.1.5 Automatic (inherent) control

The controlled quantity may be indicated adjacent to the symbol.

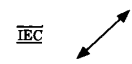

1.1.5.1 Application: Amplifier with automatic gain control

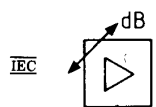

1.2.1 Temperature dependence



Add:

OR



After 1.2.5

Add:

1.2.6 Thermal effect



1.2.7 Electromagnetic effect



1.2.8 Magnetostrictive effect



After 1.3.1

Add:

1.3.1.1 Coherent radiation, non-ionizing (for example coherent light)

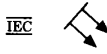

1.3.2 Radiation, ionizing

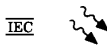

Revise the NOTE to read as follows:

NOTE 1.3.2A: If it is necessary to show the specific type of ionizing radiation, the symbol may be augmented by the addition of symbols or letters such as the following:

Alpha particle	α
Beta particle	β
Gamma ray	γ
Deuteron	d
Proton	p
Neutron	n
Pion	π
K-meson	K
Muon	μ
X ray	X

Add:

IEC Designations

α = alpha particle
β = beta particle
γ = gamma ray
δ = deuteron
ρ = proton
η = neutron
π = pion
κ = K meson
μ = muon
X = X ray

1.4.3 Solid



Add:

OR



See NOTE 1.4A

After 1.4.5

Add:

1.4.6 Material, semiconducting



1.4.7 Material, insulating



1.7 Direction of Flow of Power, Signal, or Information

Avoid conflict with symbols 9.5, 9.5.2, and 9.5.4 if used on the same diagram

1.7.1 One-way

NOTE 1.7.1A: The lower symbol is used if it is necessary to conserve space. The arrowhead in the lower symbol shall be filled.



OR



Add:

OR

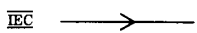

See NOTE 1.7.1A

1.7.2 Either way (but not simultaneously)



OR



Add:

OR

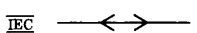

See NOTE 1.7.1A

1.7.3 Both ways, simultaneously



OR



Add:

OR

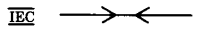

See NOTE 1.7.1A

Avoid conflict with symbol 9.2 if used on the same diagram

After 1.7.5

Add:

1.7.6 Transmission

NOTE 1.7.6A: The dot may be omitted if the sense is unambiguously given by the arrowhead in combination with the symbol to which it is applied.

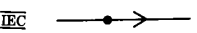

Qualifying Symbols

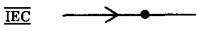
1.7.7 Reception
See NOTE 1.7.6A

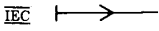

1.7.8 Energy flow from the busbars

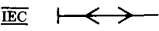
1.7.9 Energy flow towards the busbars

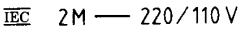
1.7.10 Bidirectional energy flow



1.8.1
Add:
The voltage may be indicated at the right of the symbol and the type of system at the left.
1.8.1.1 Application: Direct current, three conductors including midwire, 220 V (110 V between each outer conductor and midwire)
2M may be replaced by 2 + M

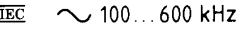

1.8.2 Alternating current

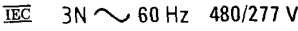
Add:
The numerical value of the frequency or the frequency range may be added at the right-hand side of the symbol.
The voltage may also be indicated to the right of the symbol.
The number of phases and the presence of a neutral may be indicated at the left-hand side of the symbol.
1.8.2.1 Application: Alternating current of 60 Hz



1.8.2.2 Application: Alternating current frequency range 100 kHz to 600 kHz



1.8.2.3 Application: Alternating current: three-phase with neutral, 60 Hz, 480 V (277 V between phase and neutral).
3N may be replaced by 3 + N

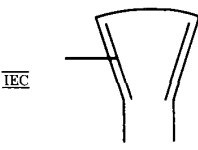

1.8.2.4 Neutral
This symbol for neutral is given in IEC Publication 445 (1973) [11].



1.8.2.5 Midwire
This symbol for midwire is given in IEC Publication 445 (1973) [11].



After 1.10.4
Add:
1.10.5 Conductive coating on internal surface of envelope

Add:
1.14 Operational Dependence On a Characteristic Quantity
1.14.1 Operating when the characteristic quantity is higher than the setting value



1.14.2 Operating when the characteristic quantity is lower than the setting value



1.14.3 Operating when the characteristic quantity is either higher than a given high setting or lower than a given low setting

1.14.4 Operating when value of the characteristic quantity becomes zero

1.14.5 Operating when the value of the characteristic quantity differs from zero by an amount which is very small compared with the normal value



1.15 Signal Identifiers
The symbol shall be used only when it is necessary to distinguish between analog and digital signals.

1.15.1 Identifier of analog signals



1.15.2 Identifier of digital signals



A time-sequence number (m) of bits may be denoted m #.

1.16 Signal Waveforms
Each symbol represents an idealized shape of the waveform.

1.16.1 Positive-going pulse

1.16.2 Negative-going pulse



1.16.3 Pulse of alternating current

1.16.4 Positive-going step function

1.16.5 Negative-going step function



1.16.6 Sawtooth

1.17 Control by Nonelectrical Quantities
Letter symbols from ANSI/IEEE Std 280-1985 [6], may be used to denote other operating quantities than those shown below (for example pressure or speed). They should be enclosed in a rectangle if ambiguity could otherwise arise.

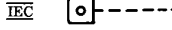
1.17.1 Control by fluid level

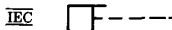
1.17.2 Control by number of events
Control by a counter

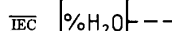

1.17.3 Control by flow

1.17.3.1 Application: Control by gas flow

1.17.4 Control by relative humidity

After 2.1.4
Add:

2.1.4.1 Application: preset adjustable resistor



2.1.7 Magnetoresistor (intrinsic) (linear type shown)

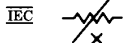

Add:

OR

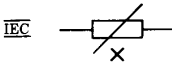

After 2.1.9
Add:

2.1.9.1 Shunt Resistor with separate current and voltage terminals

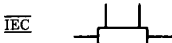

2.1.13 Symmetrical photoconductive transducer (resistive)



Add:

OR



After 2.2.2
Add:

2.2.2.1 Temperature dependent polarized capacitor, where deliberate use is made of the temperature coefficient, for example, ceramic capacitor.

NOTE 2.2.2.1A: θ may be replaced by t° .

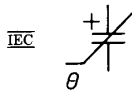

2.2.2.2 Voltage dependent polarized capacitor, where deliberate use is made of the voltage dependent characteristic, for example, semiconductor capacitor

NOTE 2.2.2.2A: U may be replaced by V .

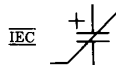

After 2.2.4
Add:

2.2.4A Capacitor with preset adjustment

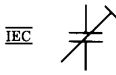

2.2.4.1 With moving element indicated

Revise NOTE 2.2.4.1A to read as follows:

NOTE 2.2.4.1A: If it is desired to indicate the moving element, the common intersection of the moving element with the symbol for variability and the connecting line is marked with a dot.

See General Symbols 2.2.1 and NOTE 2.2B

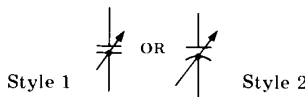

Style 1 OR Style 2

After 2.3.2
Add:

2.3.2.1 Folded dipole



2.3.2.2 Folded dipole, shown with three directors and one reflector

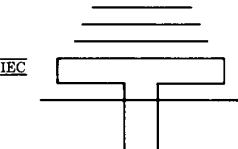

After 2.3.3
Add:

2.3.3.1 Slot antenna, shown with rectangular waveguide feeder

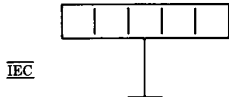

2.3.3.2 Horn antenna Horn feed



2.3.3.3 Cheese (box) reflector with horn feed, shown with rectangular waveguide feeder

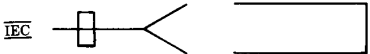

2.3.3.4 Paraboloidal antenna, shown with rectangular waveguide feeder

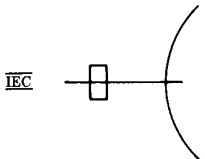

2.3.3.5 Horn-reflector antenna, shown with circular waveguide feeder

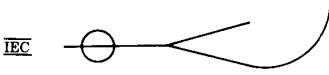

2.3.3.6 Rhombic antenna, shown terminated by a resistor

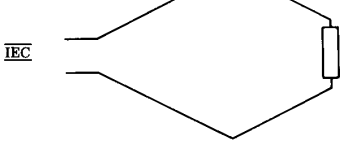

2.3.3.7 Magnetic rod antenna, for example ferrite.

If there is no risk of confusion, the general antenna symbol may be omitted.

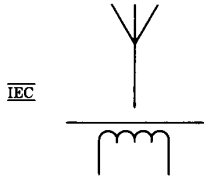

2.4 Attenuator

2.4.1 Fixed attenuator \square ; pad (general)

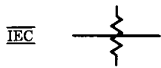

Add:

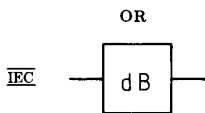

2.4.4 Variable attenuator \square (general)



Add:

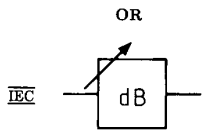

After 2.6.1

Add:

2.6.1.1 Magnetostrictive delay line shown with one input and two outputs giving delays of $50 \mu s$ and $100 \mu s$

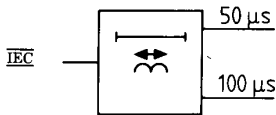

2.6.1.2 Coaxial delay line

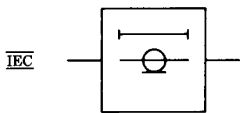

2.6.1.3 Mercury delay line with piezoelectric transducers

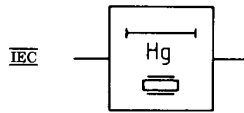

2.6.1.4 Delay line comprising an artificial line

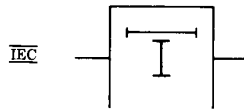

2.6.4 Slow-wave structure

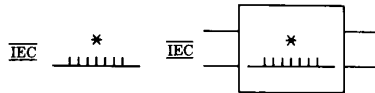

* See NOTE 2.6.1A

Add:

2.6.4.1 Open slow-wave structure (arrow indicates direction of energy flow)

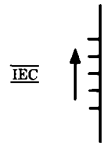

2.6.4.2 Single electrode for electrostatic focusing along open slow-wave structure

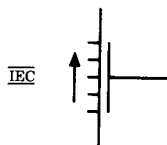

2.6.4.3 Closed slow-wave structure, shown with envelope

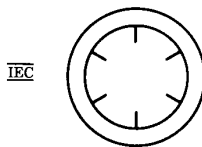

2.6.5 Delay Line Circuits

2.6.5.1 Magnetostrictive delay line with windings; three windings shown in assembled representation

NOTE 2.6.5.1A: The winding symbols may be oriented as required

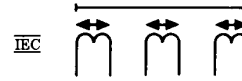

2.6.5.2 Magnetostrictive delay line with windings; one input and two outputs shown in detached representation

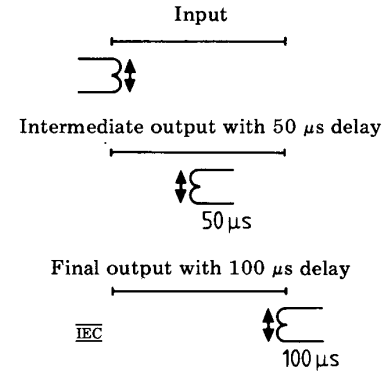

2.6.5.3 Coaxial delay line

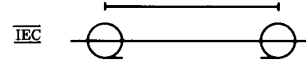

2.6.5.4 Solid material delay line with piezoelectric transducers

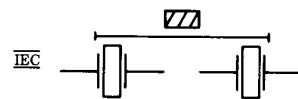

2.9.6‡ Stereo

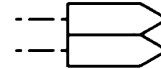

Add:

2.9.6.1 Stylus-operated stereophonic head



2.9.7 Light sensitive reproducing (reading, playback) head, monophonic

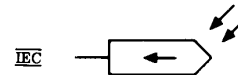

2.10 Piezoelectric Crystal Unit (including Crystal Unit, Quartz \square)

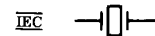

Add:

2.10.1 Piezoelectric crystal with three electrodes

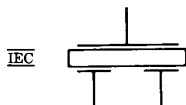

2.10.2 Piezoelectric crystal with two pairs of electrodes

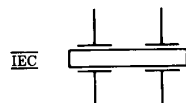

Add:

2.17.1 Ignition unit, high energy

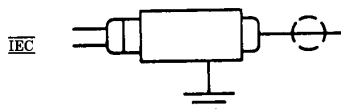

Add:

2.18 Ideal Circuit Elements

2.18.1 Ideal current source

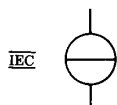

2.18.2 Ideal voltage source

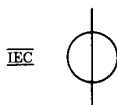

2.18.3 Ideal gyrator



2.19 Faults

2.19.1 Fault
(indication of assumed fault location)



2.19.2 Flashover Breakthrough

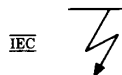

After 3.1.2.3

Add:

3.1.2.4 Flexible conductor



3.1.6 Junction of paths or conductors

After 3.1.6.3

Add:

3.1.6.3A Connection common to a group of similar items



The total number of similar items may be indicated by a figure near the common connection symbol.

3.1.6.3A.1 EXAMPLE: Multiple uniselector banks shown for 10 banks

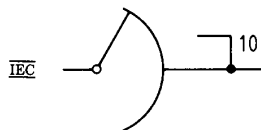

After 3.1.6.5

Add:

3.1.6.6 Neutral point in multiphase system, shown in single-line representation

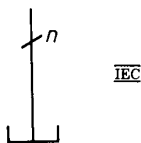

3.1.6.6.1 EXAMPLE: Synchronous generator, three-phase; both leads of each phase brought out, shown with external neutral point

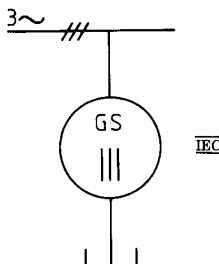

3.1.7.2 Twisted (shown with two twisted conductors)

NOTE 3.1.7.2A: The asterisk is not part of the symbol. Always replace the asterisk by one of the following letters:

P = Pair
T = Triple

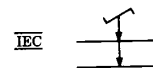

Add:

OR

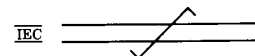

OR



*See NOTE 3.1.7.2A

After 3.1.8.6

Add:

3.1.8.7

Interchange of conductors; change of phase sequence or inversion of polarity, shown for n conductors in single-line representation.

The interchanged conductors may be indicated.

For the identification of the conductors, IEC Publication 445 (1973) [11] applies.



3.1.8.7.1 EXAMPLE: Change of phase sequence

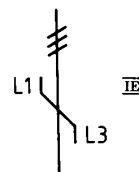

Graphic Symbols for
Transmission Path

After 3.2.6.2

Add:

3.2.7 Duct or pipe

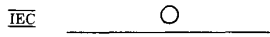

NOTE 3.2.7A: The number of ducts, the cross-section dimensions or other particulars, such as duct occupancy, may be shown above the line representing the duct route.

3.2.7.1 EXAMPLE: Line of six-way duct

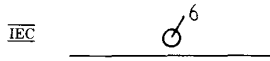

3.2.8 Line with manhole, giving access to jointing chamber

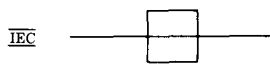

3.2.9 Straight-through joint box, shown with three conductors:

Multiline representation

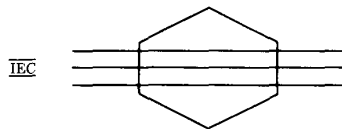

3.2.9.1 Single-line representation

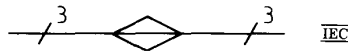

3.2.10 Junction box, shown with three conductors, with T-connections:

Multiline representation

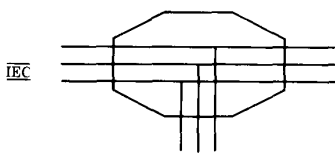

3.2.10.1 Single-line representation

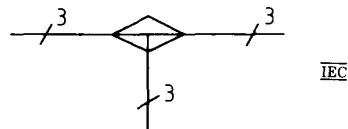

3.2.11 Line with buried jointing point

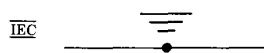

3.2.12 Line with gas or oil block

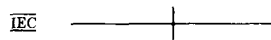

3.2.13 Line with gas or oil stop valve

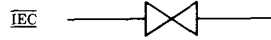

3.2.14 Line with gas or oil block by-pass

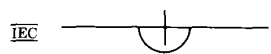

3.2.15 Power feeding

3.2.15.1 Power feeding (ac) on telecommunication lines

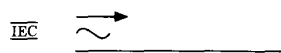

3.2.15.2 Power feeding (dc) on telecommunication lines

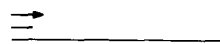

3.2.16 Anticreepage device

Anticreepage device for cable

NOTE 3.2.16A: The symbol should be shown on the creepout side of the manhole.

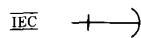

3.2.16.1 EXAMPLE: Manhole equipped with anticreepage device for cable (Creepage to the left is prevented)

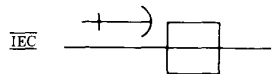

3.2.17 Overground, weatherproof enclosure, general symbol

NOTE 3.2.17A: Qualifying symbols or designations may be used to indicate the apparatus contained in the enclosure.

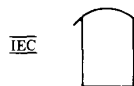

3.2.17.1 EXAMPLE: Amplifying point in a weatherproof enclosure



3.2.18 Crossconnection point

NOTE 3.2.18A: Inlets and outlets may be oriented as required.



3.2.19 Line concentrator Automatic line connector



3.2.19.1 EXAMPLE: Line concentrator on a pole

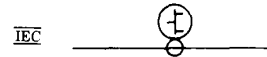

3.2.20 Protective anode

NOTE 3.2.20A: The type of anode material may be indicated by adding its chemical letter symbol.



3.2.20.1 EXAMPLE: Magnesium protective anode

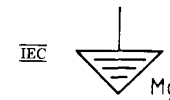

After 3.6.7

Add:

3.6.8 Optical fiber

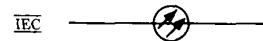

After 3.10

Add:

3.10.1 Pressure-tight bulkhead cable gland; shown with three cables

NOTE 3.10.1A: The high-pressure side is the longer side of the trapezoid thus retaining gland in bulkhead.

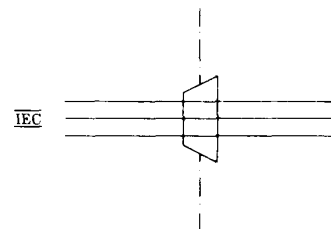

4.1 Switching Function

NOTE 4.1A: Switching function symbols are suitable for use on *detached contact* diagrams, but may be used in other applications.

Add:

4.1A Qualifying Symbols for Contacts (IEC Publication 617-7 (1983) [18])

4.1A.1 Contactor function



4.1A.2 Circuit-breaker function



4.1A.3 Disconnecter (isolator) function



4.1A.4 Switch-disconnector (isolating-switch) function



4.1A.5 Automatic release function



**4.1A.6 Position switch function
Limit switch function**

NOTE 4.1A.6A: This qualifying symbol can be applied to simple contact symbols to indicate position or limit switches if there is no need to show the means of operating the contact. In complicated cases, where it is desirable to show the means of operation, symbols 14.4.16 to 14.4.16.3 should be used instead.

NOTE 4.1A.6B: This symbol is placed on both sides of the contact symbol when the contact is mechanically operated in both directions.



4.1A.7 Spring return function

NOTE 4.1A.7A: This symbol may be used to indicate spring return function. When this convention is invoked its use should be appropriately referenced.

NOTE 4.1A.7B: This symbol should not be used together with qualifying symbols 4.1A.1, 4.1A.2, 4.1A.3, and 4.1A.4. In many cases, symbol 14.5.1 may be used.



4.1A.8 Nonspring return (stay put) function

NOTE 4.1A.8A: This symbol may be used to indicate nonspring return function. When this convention is invoked, its use should be appropriately referenced.

NOTE 4.1A.8B: This symbol should not be used together with qualifying symbols 4.1A.1, 4.1A.2, 4.1A.3, and 4.1A.4. In many cases, symbol 14.5.2 may be used.



4.3 Basic Contact Assemblies

The standard method of showing a contact is by a symbol indicating the circuit condition it produces when the actuating device is in the de-energized or nonoperated position. The actuating device may be of a mechanical, electrical, or other nature, and a clarifying note may be necessary with the symbol to explain the proper point at which the contact functions; for example, the point where a contact closes or opens as a function of changing pressure, level, flow, voltage, current, etc. In cases where it is desirable to show contacts in the energized or operated condition and where confusion may result, a clarifying note shall be added to the drawing.

For designations of auxiliary switches or contacts for circuit breakers, etc, see ANSI/IEEE C37.2-1979 [3].

Add:

4.3A IEC Publication 617-7 (1983) [18] Coordinated System

This section provides preferred symbols for contact units and switchgear. Each symbol depicts the function of a contact or a switching device, without necessarily being related to the construction of the device it represents.

A small circle, open or filled in, representing the hinge-point may be added to most of the symbols for contacts, switches, and controlgear. See for example 4.3A.1.1.1.

For clarity this symbol must be shown on some symbols, see for example 4.3A.1.4.

4.3A.1 Contacts with two or three positions

4.3A.1.1 Make contact

NOTE 4.3A.1.1A: This symbol is also used as the general symbol for a switch.

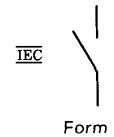

4.3A.1.1.1

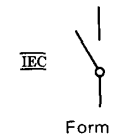

4.3A.1.2 Break contact

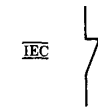

4.3A.1.3 Change-over break before make contact

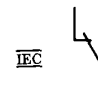

4.3A.1.4 Two-way contact with center-off position

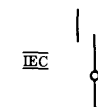

4.3A.1.5 Changeover make before break contact (bridging)

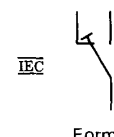

4.3A.1.5.1

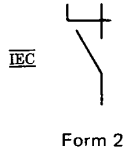

4.3A.1.6 Contact with two makes

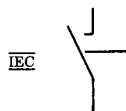

4.3A.1.7 Contact with two breaks

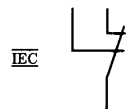

4.3A.2 Passing contacts with two positions

4.3A.2.1 Passing make contact closing momentarily when its operating device is actuated

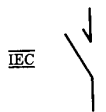

4.3A.2.2 Passing make contact closing momentarily when its operating device is released

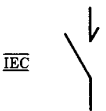

4.3A.2.3 Passing make contact closing momentarily when its operating device is actuated or released

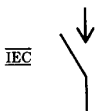

4.3A.3 Early and late operating contacts

4.3A.3.1 Make contact (of a multiple contact assembly) which is early to close relative to the other contacts of the assembly

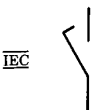

4.3A.3.2 Make contact (of a multiple contact assembly) which is late to close relative to the other contacts of the assembly

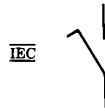

4.3A.3.3 Break contact (of a multiple contact assembly) which is late to open relative to the other contacts of the assembly



4.3A.3.4 Break contact (of a multiple contact assembly) which is early to open relative to the other contacts of the assembly

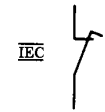

4.3A.4 Examples of contacts with intentional delay

4.3A.4.1 Make contact delayed when closing (operating device actuated)

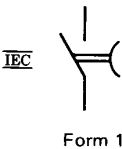

4.3A.4.2

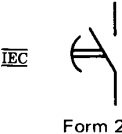

4.3A.4.3 Break contact delayed when reclosing (operating device released)

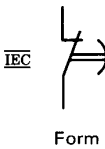

4.3A.4.4

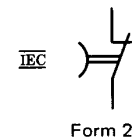

4.3A.4.5 Make contact delayed when closing and opening

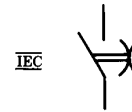

4.3A.4.6 Contact assembly with one make contact not delayed, one make contact delayed when reopening and one break contact delayed when opening

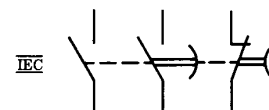

4.3A.5 Examples of spring return and nonspring return (stay put) contacts

4.3A.5.1 Make contact with spring return

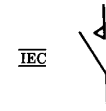

4.3A.5.2 Make contact without spring return (stay put)

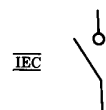

4.3A.5.3 Break contact with spring return

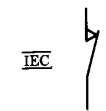

4.3A.5.4 Two-way contact with center-off position with spring return from the left-hand position but not from the right-hand one (stay put)

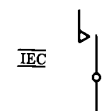

Add:

4.3B ANSI/IEEE Std 315-1975 [7] System

4.3.1 Closed contact (break)

⋮

⋮ No change in existing symbols but IEC approval will be withdrawn in the future.

4.3.8.3

Add:

4.6.3 Indication of operating method

Former 4.6.3 is now 4.6.3.5

Devices with *push* or *pull* operation normally have spring return. It is therefore not necessary to show the automatic return symbol (14.5.1). On the other hand, a detent symbol (14.5.2) should be shown in the exceptional cases where locking exists.

Devices operated by turning do not usually have automatic return. It is therefore not necessary for the detent symbol (14.5.2) to be shown. On the other hand, the automatic return symbol (14.5.1) should be shown in those cases where an automatic return exists.

4.6.3.1 Manually operated switch; general symbol

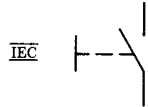

4.6.3.2 Push-button switch (non-locking)

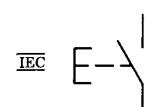

4.6.3.3 Pull-switch (nonlocking)

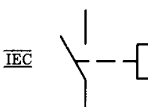

4.6.3.4 Turn-switch (locking)

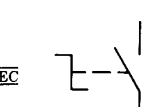

4.6.3.5 Knife switch $\overline{\text{E}}$, general



4.14.5.3 Normally closed



Add:

OR



After 4.14.5.4

Add:

4.14.5.5 Position or limit switch mechanically operated in both directions with two separate circuits

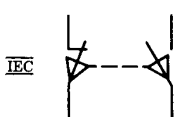

4.21.1 Closes on rising temperature



See NOTE 4.21A

Add:

OR

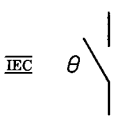

4.21.2 Opens on rising temperature



See NOTE 4.21A

Add:

OR

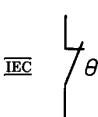

4.22 Flasher Self-Interrupting Switch



OR



Add:

4.22.1 Self-operating thermal switch, break contact

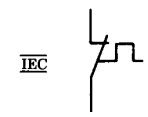

NOTE 4.22.1A: It is important to distinguish between a contact as shown and a contact of a thermal relay, which in detached representation may be shown as follows:



4.22.2 Gas discharge tube with thermal element Starter for fluorescent lamp

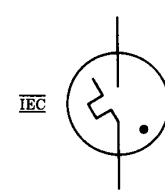

Revise 4.29.1 to read as follows:

4.29.1 Manually operated 3-pole contactor

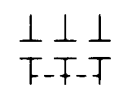

After 4.33
Add:

4.34 Multipole and Multiposition Switches (IEC Publication 617-7 (1983) [18])

4.34.1 Key operated lever or turn switches (compare with 4.12 items)

4.34.1.1 Three position lever-operated switch, locking in the upper position and with spring return from the lower position to the middle one, shown with terminals

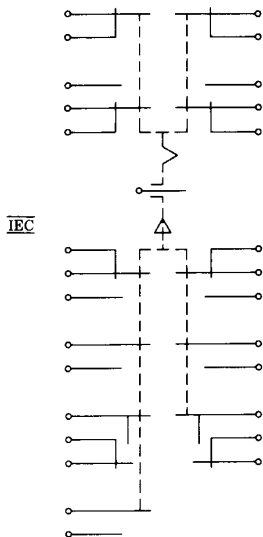

4.34.1.2 Button-operated switch in which one set of contacts is operated by pushing the button (nonlocking) and another set by turning it (locking), shown with terminals

The bracket indicates that there is only one actuator

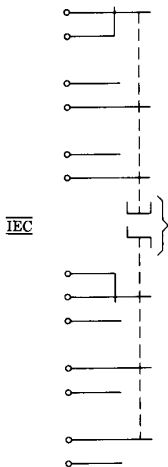

4.34.1.3 Button-operated switch in which the same set of contacts may be operated in two different ways; either by turning (with locking) or pushing (with spring return), shown with terminals

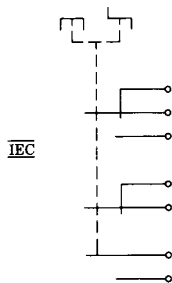

4.34.2 Multiposition Switches

4.34.2.1 Single-pole n-position switch, shown for $n = 6$

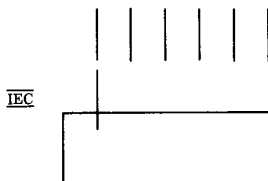

4.34.2.2 Single-pole n-position switch, alternative for use when n is small, shown for $n = 4$

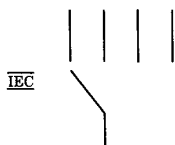

4.34.2.3 Example with position diagram

NOTE 4.34.2.3A: It is sometimes convenient to indicate the purpose of each switch position by adding text to the position diagram. It is also possible to indicate limitations of movement of the operating device as in the examples which follow:

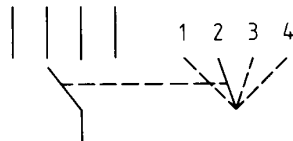

The operating device (for example handwheel) can be turned only from positions 1 to 4 and back.

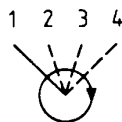

The operating device can be turned in the clockwise direction only.

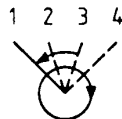

The operating device can be turned in the clockwise direction without limitation and may be turned in the counter-clockwise direction only between positions 3 and 1.

4.34.2.4 Four-position switch, manually operated, having four independent circuits

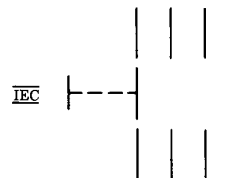

4.34.2.5 Single-pole, four-position switch in which position 2 cannot be connected

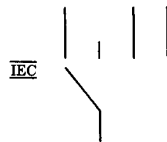

4.34.2.6 Single-pole, six-position switch with a wiper that bridges only while passing from one position to the next

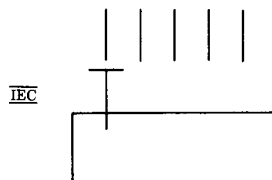

4.34.2.7 Single-pole multiposition switch with a wiper that bridges three consecutive terminals in each switch position

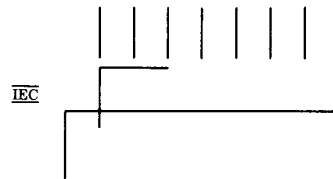

4.34.2.8 Single-pole multiposition switch with a wiper that bridges four terminals but omits one intermediate terminal in each switch position

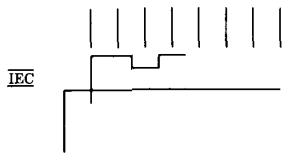

4.34.2.9 Single-pole multiposition switch for cumulative parallel switching

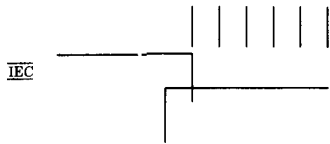

4.34.2.10 One pole of a six-position multipole switch

The pole shown makes earlier than the other poles when the wiper moves from position 2 to 3 and breaks later than the other poles when the wiper moves from position 5 to 6. When the wiper moves in the opposite direction the early make becomes a late break and vice versa

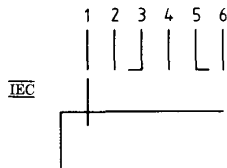

4.34.3 Block Symbols for Complex Switches

There are many ways in which complex switching functions can be achieved mechanically, for example by rotary wafer switches, slide switches, drum controllers, cam-operated contact assemblies, etc. There are also many ways in which the switching functions may be symbolized on circuit diagrams. Study has shown that there is no unique system of symbolization which is superior in every application. The system employed should be chosen with due regard to the purpose of the diagram and the degree of complexity of the switching device it is desired to symbolize. This section therefore presents one possible method of symbolizing complex switches. To facilitate understanding each example includes a constructional drawing of the device symbolized. The method shown here uses a general symbol for a complex switch which must be supplemented by a table of connections. Two examples are shown.

4.34.3.1 Complex switch, general symbol

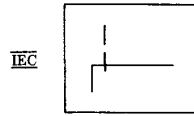

4.34.3.2 EXAMPLES: 18-position rotary wafer switch with six terminals, here designated A to F, constructed as shown in the bottom diagram (switch shown in position 1)

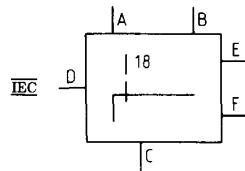
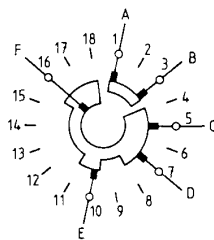
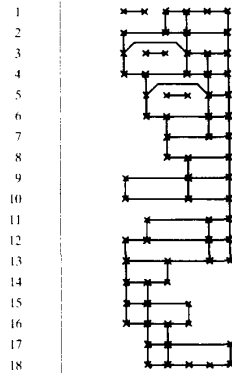

Table of connections

Position	Interconnections of terminals					
	A	B	C	D	E	F



4.34.3.3 EXAMPLE: Six-position rotary drum switch with five terminals, constructed as shown in the bottom diagram

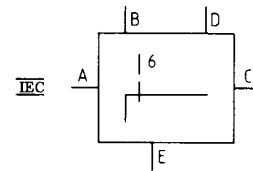
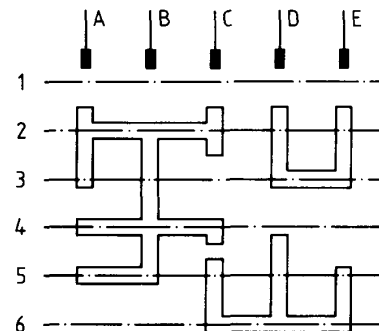

Table of connections

Position	Interconnections of terminals				
	A	B	C	D	E
1	+		+	○	○
2	+	+	+	○	○
3	+	+	+	○	○
4	+	+	+	○	○
5	+	+	+	○	○
6					



The symbols + - and O indicate the terminals that are connected together at any position (rest-position or intermediate position) of the switch, that is, terminals having the same indicating symbol for example, + are interconnected

NOTE 4.34.3.3A: Where additional symbols are required, the characters available on a typewriter should be used, for example, x, =.

4.35 Switchgear and Controlgear
4.35.1 Switch (mechanical)

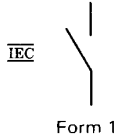

Form 1

OR

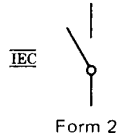

Form 2

4.35.2 Contactor (contact open in the unoperated position)

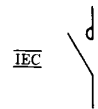

4.35.3 Contactor with automatic release

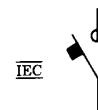

4.35.4 Contactor (contact closed in the unoperated position)

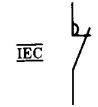

4.35.5 Circuit breaker

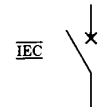

4.35.6 Disconnecter (isolator)

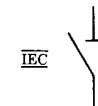

4.35.7 Two-way disconnector (isolator) with center-off position

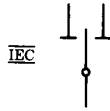

4.35.8 Switch-disconnector (on-load isolating switch)

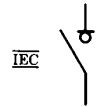

4.35.9 Switch-disconnector with automatic release

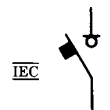

4.35.10 Disconnecter (isolator) with blocking device, manually operated

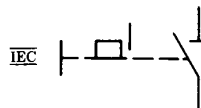

4.36 Block Symbols for Motor Starters
4.36.1 Motor starter, general symbol

NOTE 4.36.1A: Qualifying symbols may be shown inside the general symbol to indicate particular types of starters. See symbols 4.36.5, 4.36.7, and 4.36.8.



4.36.2 Starter operated in steps

NOTE 4.36.2A: The number of steps may be indicated.



4.36.3 Starter-regulator



4.36.4 Starter with automatic release



4.36.5 Direct on line contactor starter for reversing motor
Full voltage contactor starter for reversing motor

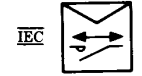

4.36.6 Star-delta starter

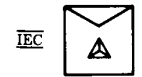

4.36.7 Autotransformer starter

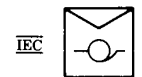

4.36.8 Starter-regulator with thyristors

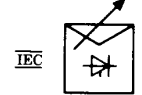

4.37 Operating Devices for Electro-mechanical (all or nothing) Relays

4.37.1 Operating device, general symbol

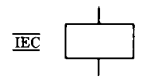

Form 1

4.37.2

NOTE 4.37.2A: Operating devices with several windings may be indicated by inclusion of the appropriate number of inclined strokes or by repeating symbol 4.37.1 or 4.37.2.

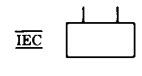

Form 2

4.37.3 *EXAMPLES:* Operating device with two separate windings, assembled representation

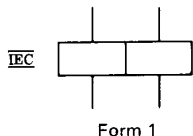

4.37.4

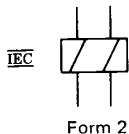

4.37.5 Operating device with two separate windings, detached representation

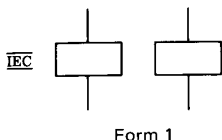

4.37.6

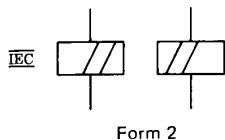

4.37.7 Relay coil of a slow-releasing relay

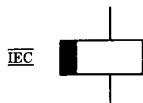

4.37.8 Relay coil of a slow-operating relay

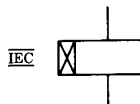

4.37.9 Relay coil of a slow-operating and slow-releasing relay

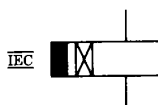

4.37.10 Relay coil of a high-speed relay (fast operating and fast releasing)

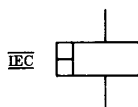

4.37.11 Relay coil of a relay unaffected by alternating current

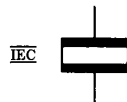

4.37.12 Relay coil of an alternating current relay

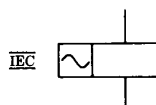

4.37.13 Relay coil of a mechanically resonant relay

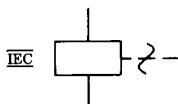

4.37.14 Relay coil of a mechanically latched relay

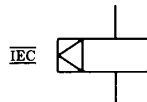

4.37.15 Relay coil of a polarized relay

NOTE 4.37.15A: Dots may be used to indicate the relationship between the direction of the current through the winding of a polarized relay and the movement of the contact arm.

When the winding terminal identified by the polarity dot is positive with respect to the other winding terminals, the contact arm moves or tends to move towards the position marked with the dot.

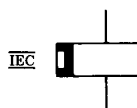

4.37.16 *EXAMPLES:* Polarized relay, self restoring, operating for only one direction of current in the winding

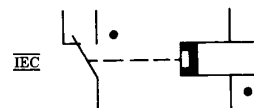

4.37.17 Polarized relay with neutral position, self restoring, operating for either direction of current in the winding



4.37.18 Polarized relay with two stable positions



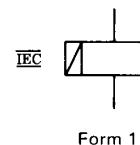

4.37.19 Relay coil of a remanent relay

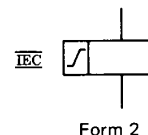

4.37.20



**5.3 Connector
Disconnecting Device
Jack 
Plug **

The contact symbol is not an arrow-head. It is larger and the lines are drawn at a 90° angle.

5.3.1 Female contact

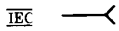

Add:

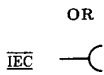

5.3.2 Male contact

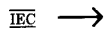

Add:

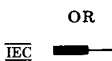

Revise 5.3.4.1 to read as follows:

5.3.4.1 Application: engaged 4-conductors (male plug - female receptacle shown)

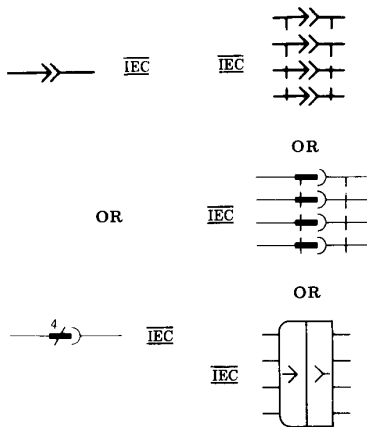

5.3.5.1 2-conductor (jack)

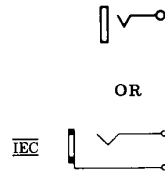

5.3.5.2 2-conductor (plug)

Add:

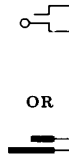

5.3.5.3‡ 3-conductor (jack) with 2 break contacts (normals) and 1 auxiliary make contact

Add:

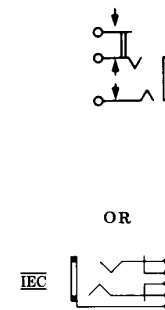

5.3.5.4 3-conductor (plug)

Add:

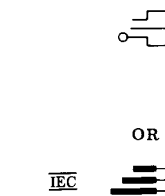

5.3.5.5 Break or isolating jack, telephone type

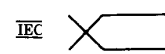

After 5.3.6.4

Add:

5.3.7 Adapter

5.3.7.1 Plug and socket-type connector, for example U-link: male-male.

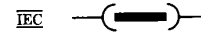

5.3.7.2 Male-female



5.3.7.3 Male-male with socket access

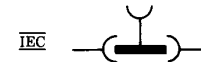

5.3.8 Butt-connector



5.3.9 Connecting link, closed

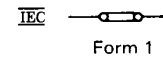

5.3.9.1

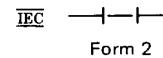

5.3.9.2 Connecting link, open

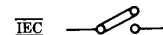

After 5.6.1

Add:

5.6.1A Coaxial plug and socket

NOTE 5.6.1A: If the coaxial plug or socket is connected to a coaxial pair, the tangential line(s) should be appropriately extended.



6.1.2 Magnetic core of inductor or transformer

Not to be used unless it is necessary to identify a magnetic core.



Add:

OR

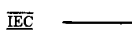

Revise 6.2.1 to read as follows:

6.2.1 General

NOTE 6.2.1A: This symbol is deprecated and should not be used on new schematics.



OR



See NOTE 6.2.1A

Add:

6.2.1A Choke Reactor

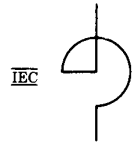

See NOTE 6.4.1A

6.2.2 Magnetic-core inductor
Telephone loading coil

If necessary to show a magnetic core.



Add:

OR



6.2.2.1 Inductor with gap in magnetic core



Add:

6.2.4.1 Inductor with moving contact, variable in steps



After 6.2.5
Add:

6.2.5A Variometer

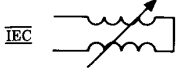

6.2.9 See new 11.3.3

After 6.2.9
Add:

6.2.10 Coaxial choke with magnetic core

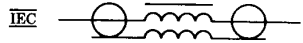

6.2.11 Ferrite bead, shown on a conductor

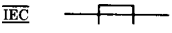

See also 15.18.1

Revise NOTE 6.4.1A to read as follows:

NOTE 6.4.1A: This symbol is the preferred single-line symbol in IEC Publication 617-6 (1983) [17]. It should be used on schematics for equipments having international usage, especially when the equipment will be marked using this symbol (in accordance with IEC Publication 417 (1973) [10]).

6.4.2.3 Application: transformer with magnetic core shown and with an electrostatic shield between windings. The shield is shown connected to the frame.

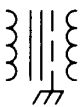

Add:

6.4.2.3A Single-phase transformer with two windings and screen.

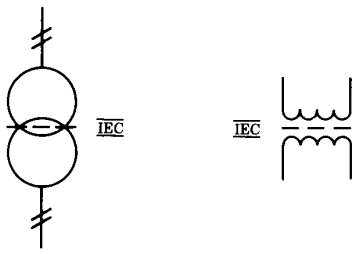

Revise 6.4.4 to read as follows:

6.4.4 One winding with adjustable inductance

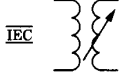

OR

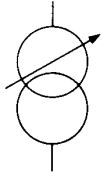

See NOTE 6.4.4A

See NOTE 6.4.1A

NOTE 6.4.4A: The former right-hand ⊕ symbol has been deleted. It is no longer recommended for use on complete diagrams.

6.4.6 Adjustable mutual inductor; constant-current transformer



Add:

OR

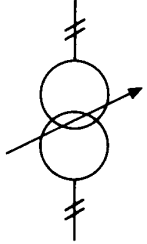

6.4.7 With taps, 1-phase



Graphic Symbols for
Transformers, Inductors, and Windings

Add:

6.4.7A Transformer with center tapping on one winding

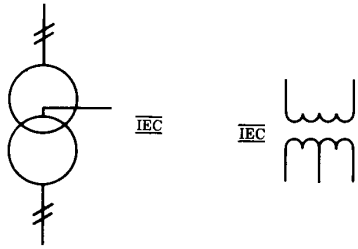

Revise 6.4.8 to read as follows:

6.4.8 Autotransformer, 1-phase



OR

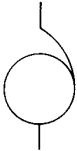

IEC

See NOTE 6.4.4A

See NOTE 6.4.1A

Add:

6.4.8A Autotransformer, three-phase, star connection

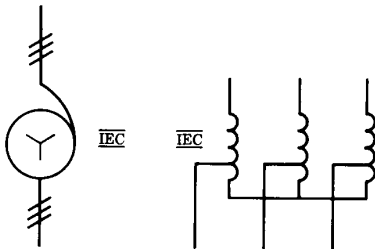

Revise 6.4.9 to read as follows:

6.4.9 Adjustable



OR



IEC

See NOTE 6.4.4A

See NOTE 6.4.1A

Revise 6.4.12 to read as follows:

6.4.12 1-phase induction voltage regulator(s)

Number of regulators may be written adjacent to the symbol.



OR



OR

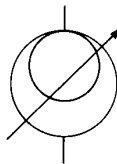

IEC

See NOTE 6.4.4A

See NOTE 6.4.1A

Revise 6.4.14 to read as follows:

6.4.14 3-phase induction voltage regulator



OR

OR

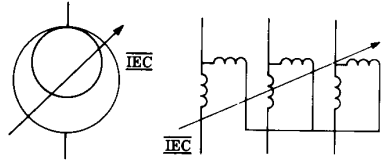

See NOTE 6.4.4A

See NOTE 6.4.1A

Revise 6.4.15 to read as follows:

6.4.15 1-phase, 2-winding transformer



OR

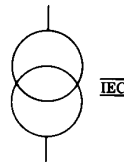

IEC

See NOTE 6.4.4A

See NOTE 6.4.1A

Revise 6.4.15.1 to read as follows:

6.4.15.1 Application: 3-phase bank of 1-phase, 2-winding transformers with wye-delta connections

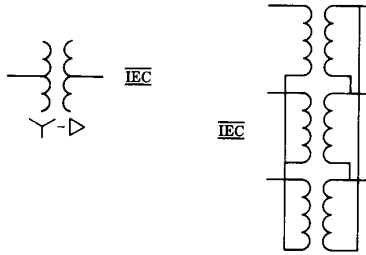

OR

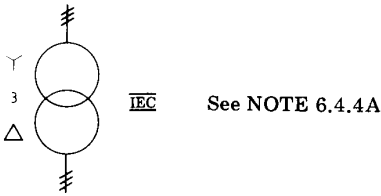

See NOTE 6.4.1A

The alternate symbol has been corrected to conform to IEC Publication 617-6 (1983) [17]. Shown outside the symbol is Y. Reason: Three separate transformers.

Revise 6.4.15.2 to read as follows:

6.4.15.2 Three-phase transformer with 4 taps with wye-wye connections

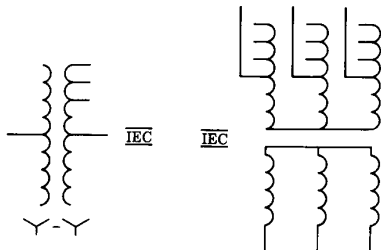

OR

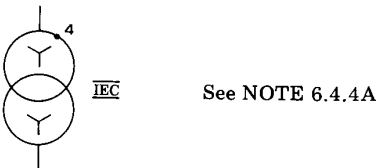

See NOTE 6.4.1A

6.4.16 Polyphase transformer

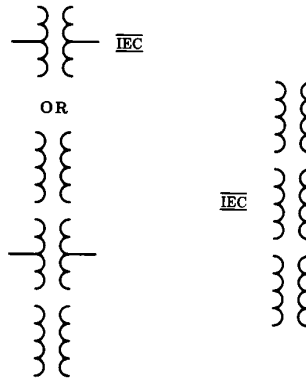

Add:

6.4.16A.1 Three-phase transformer, connection star-delta

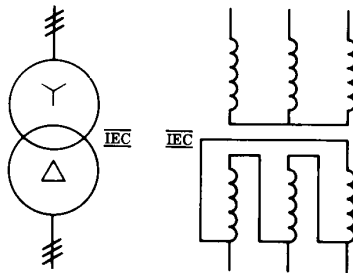

6.4.16A.2 See 6.4.15.2

6.4.16A.3 Three-phase transformer with on-load tap changer, connection star-delta

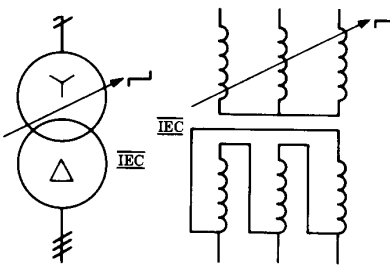

6.4.16A.4 Three-phase transformer, connection star-zigzag

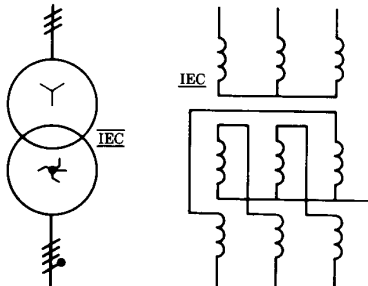

6.4.16A.5 Three-phase transformer, connection star-star-delta

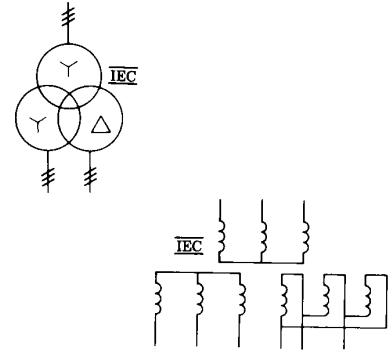

Revise 6.4.17 to read as follows:

6.4.17 1-phase, 3-winding transformer

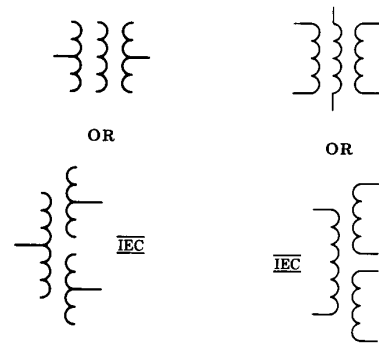

OR

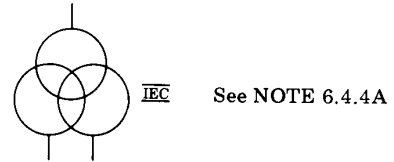

See NOTE 6.4.1A

6.4.18 Current transformer(s)

Avoid conflict with symbol 3.2.5 if used on the same diagram.

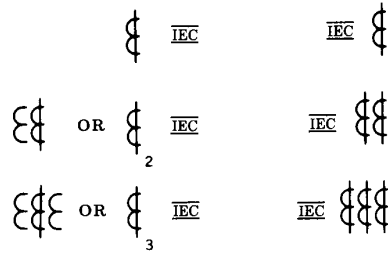

Add:

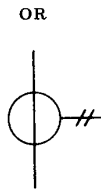

6.4.18.1 Current transformer with two cores and two secondary windings

The terminal symbols shown at each end of the primary circuit indicate that only a single device is represented.

NOTE 6.4.18.1A: In the right-hand symbol core symbols may be omitted.

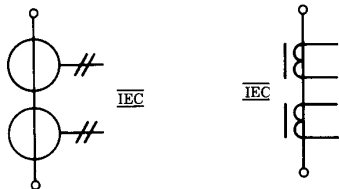

6.4.18.2 Current transformer with two secondary windings on one core.

NOTE 6.4.18.2A: In the right-hand symbol the core symbol shall be drawn.

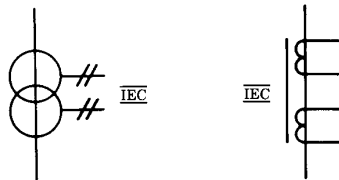

6.4.18.3 Current transformer with one secondary winding with three tapings

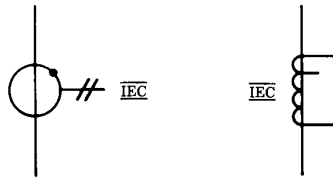

6.4.18.4 Current transformer where the primary conductor forms five winding turns

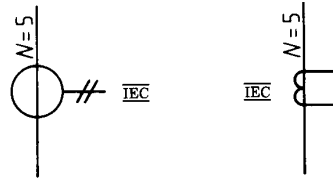

6.4.18.5 Pulse or current transformer with one permanent winding and three threaded windings

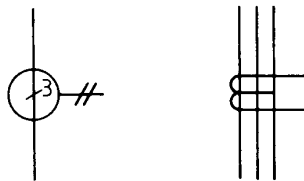

6.4.18.6 Pulse or current transformer with two permanent windings on the same core and with nine threaded windings

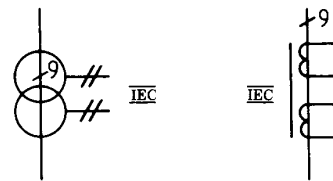

6.4.20 Potential transformer(s)

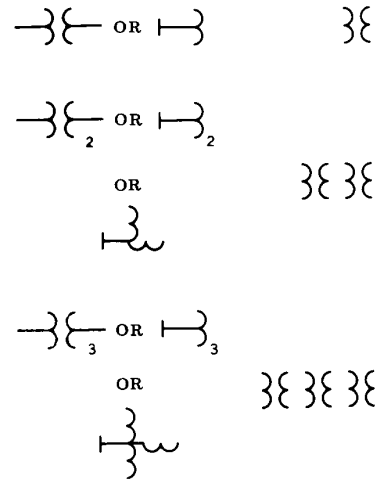

Add:

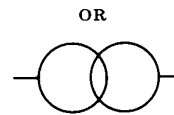

After 6.5
Add:

6.6 Ferrite Cores—Symbol Elements
(IEC Publication 617-4 (1983) [15])
6.6.1 Ferrite core



6.6.2 Flux/current direction indicator

This symbol indicates that a horizontal line drawn at a right angle through a core symbol represents a core winding, and it also gives the relative directions of current and flux.

NOTE 6.6.2A: This symbol is not applicable for topographical representation.

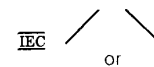

6.6.3 Ferrite core with one winding



The oblique line may be regarded as a reflector that relates the directions of current and flux as shown below.

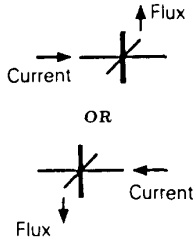

For drawing convenience, lines representing conductors are often shown crossing even core symbols even though there is no winding on the magnetic circuit. Except in topographical representation the use of the oblique stroke is mandatory in all cases where a line through the core symbol represents a winding.

EXAMPLE:

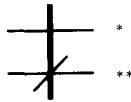

* Conductor crossing the core symbol
** Winding on the core

6.7 Ferrite Cores (IEC Publication 617-4 (1983) [15])

6.7.1 Ferrite core with five windings

NOTE 6.7.1A: Information on the direction of current, its relative amplitude and the logic conditions imposed by the state of the magnetic remanence may be added.

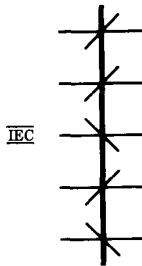

6.7.2 Ferrite core with one winding of m turns



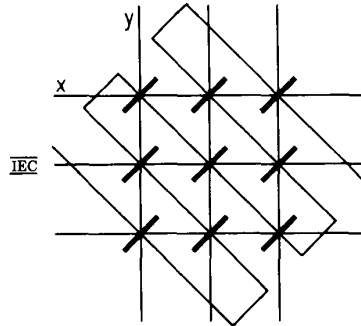

6.8 Magnetic Storage Matrices (Topographical Representation)

6.8.1 Ferrite core matrix with x and y windings and a readout winding. The symbol of a ferrite core, 6.6.1, is shown at 45° to the horizontal.

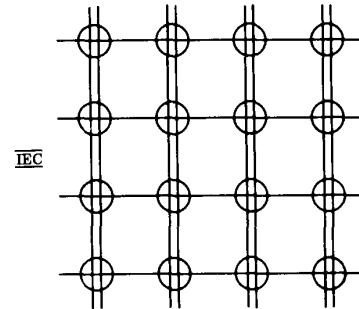

6.8.2 Matrix arrangement comprising thin sheet magnetic stores, located between thin sheet wiring layers.





7.1.1.1 Directly heated (filamentary) cathode
NOTE 7.1.1.1A: Leads may be connected in any convenient manner to ends of the  provided the identity of the  is retained.

 See NOTE 7.1.1.1A

Add:

OR



7.1.1.2 Indirectly heated cathode
Lead may be connected to either extreme end of the  or, if required, to both ends, in any convenient manner.



Add:

OR

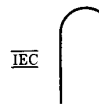



After 7.1.1.6

Add:

7.1.1.7 Photoemissive electrode



7.1.2.1 Grid 
Beam-confining or beam-forming electrodes



Add:

7.1.2.1.1 Grid with secondary emission



Revise 7.1.2.2 to read as follows:

7.1.2.2 Deflecting electrodes (used in pairs)



OR



7.1.2.2A Radial deflecting electrodes, one pair of electrodes shown

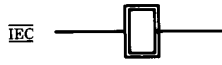

After 7.1.2.4

Add:

7.1.2.5 Ion diffusion barrier



7.1.2.6 Intensity modulating electrode

NOTE 7.1.2.6A: Symbol 7.1.2.1 may be used if no confusion will arise.

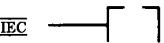

7.1.2.7 Focusing electrode with aperture
Beam-forming plate

See NOTE 7.1.2.6A

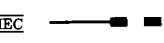

7.1.2.8 Beam-splitting electrode internally connected to the final focusing electrode of the electron gun



7.1.2.9 Cylindrical focusing electrode
Drift space electrode

Electronic lens element

See NOTE 7.1.2.6A



7.1.2.10 Cylindrical focusing electrode with grid



7.1.2.11 Multiaperture electrode

See NOTE 7.1.2.6A

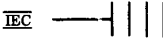

7.1.2.12 Quantizing electrode
Sampling electrode



7.1.5 Heater



See NOTE 7.1.1.1A

Add:

OR



After 7.1.8

Add:

7.1.9 Storage electrodes
7.1.9.1 Storage electrode



7.1.9.2 Photoemissive storage electrode



7.1.9.3 Storage electrode with secondary emission in the direction of the arrow

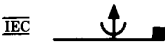

7.1.9.4 Photoconductive storage electrode



7.1.10 Symbol elements for microwave tubes
7.1.10.1 Electron gun assembly, shown with envelope

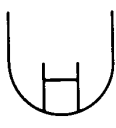

Simplified Form

7.1.10.2 Reflector
Repelling electrode (used in velocity modulated tubes)



7.1.10.3 Nonemitting sole for open slow-wave structure

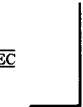

**Graphic Symbols for
Electron Tubes and Related Devices**

7.1.10.4 Nonemitting sole for closed slow-wave structure

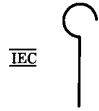

7.1.10.5 Emitting sole (arrow indicates direction of electron flow)

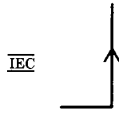

7.3.6.1 With electric-field (electrostatic) deflection

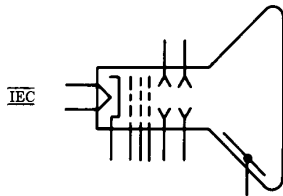

Add:

7.3.6.1.1 Double-beam cathode-ray tube, split-beam type with:
Electrostatic deflection
Indirectly heated cathode

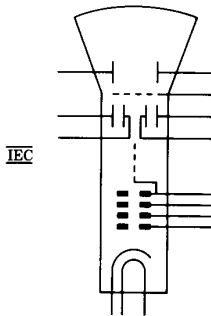

Add:

7.3.6.2.3 Cathode-ray tube with electromagnetic deviation, with:
— Permanent magnet focusing and ion trap
— Intensity modulating electrode
— Indirectly heated cathode
For example, television picture tube

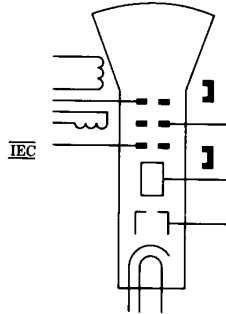

7.4 Solion
Ion-Diffusion Device

7.4.1 Diode solion

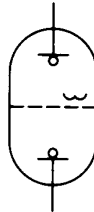

Add:

OR

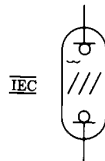

7.4.2 Tetrode solion

NOTE 7.4.2A: Letters in parentheses are not part of the symbol.

I Input
S Shield
R Readout
C Common

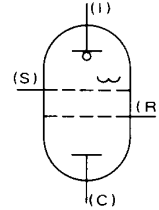

Add:

OR

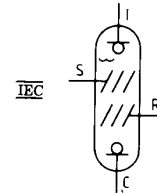

See NOTE 7.4.2A

7.5 Coulomb Accumulator
Electrochemical Step-Function Device

NOTE 7.5A: Letters in parentheses are not part of the symbol, but are for explanation only. For a precharged cell, with + polarity applied to P, the cell internal resistance and voltage drop will remain low until the designed coulomb quantity has passed; then the internal resistance will rise to its high value.



See NOTE 7.5A

Add:

OR

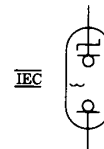

Revise 7.7.1 to read as follows:

7.7.1 General

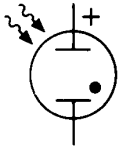

See NOTE 7.7A

Revise 7.7.2 to read as follows:

7.7.2 Application: metal enclosure, having one collector connected to the enclosure

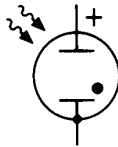

See NOTE 7.7A

After 7.7.2

Add:

7.7.3 Ionizing radiation detectors
7.7.3.1 Ionization chamber

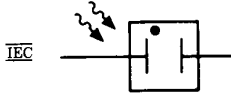

7.7.3.2 Ionization chamber with grid

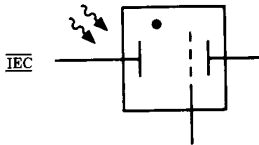

7.7.3.3 Ionization chamber with guard ring

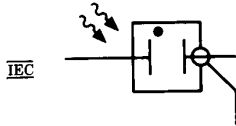

7.7.3.4 Ionization chamber, compensated type

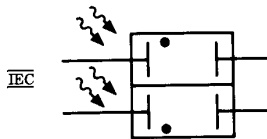

7.7.3.5 Faraday cup

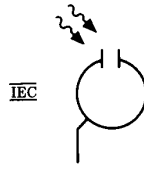

7.7.3.6 Counter tube

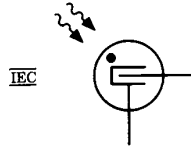

7.7.3.7 Counter tube with guard ring

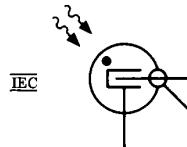

Revise 8.2.2 to read as follows:

8.2.2 Rectifying junction or junction which influences a depletion layer

Arrowheads () shall be half the length of the arrow away from the semiconductor base region.

See item 8.6

The equilateral () triangle shall be filled and shall touch the semiconductor base-region symbol.

NOTE 8.2.2A: The triangle points in the direction of the forward (easy) current as indicated by a direct-current ammeter, unless otherwise noted adjacent to the symbol. Electron flow is in the opposite direction.

Add:

8.2.2A Rectifying junction

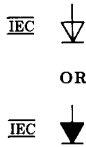

Revise:

8.2.2.1 P region on N region

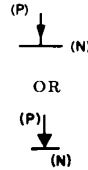

Add:

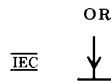

Revise:

8.2.2.2 N region on P region

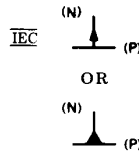

Add:

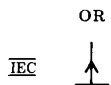

8.2.3 Enhancement-type semiconductor region with plurality of ohmic connections and a rectifying junction

Portions of the interrupted channel line having ohmic contacts shall be of equal length and drawn significantly longer than the center-channel section. Channel gaps shall be of equal length and approximately equal to the center-channel length.



Add:

8.2.3A Indication of the conductivity type of the channel for insulated gate field effect transistors (IGFET)

8.2.3A.1 N-type channel on P-type substrate, shown for a depletion type IGFET

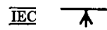

8.2.3A.2 P-type channel on an N-type substrate, shown for an enhancement type IGFET

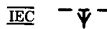

8.2.4.1 P emitter on N region



Add:

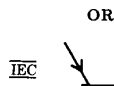

8.2.4.1.1 Plurality of P emitters on N region



Add:

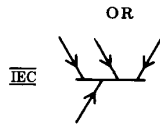

8.2.4.2 N emitter on P region



Add:



8.2.4.2.1 Plurality of N emitters on P region



Add:

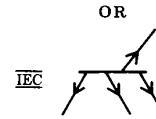

CORRECTION: Symbol was omitted in some printings.

8.2.9.2 Gate (no external connection)

For application, see symbol 8.5.9

Because there is no external connection to the gate, this lead shall not extend to the envelope symbol, if any.

Style 3 

See NOTE 8.2.9A

8.3.1 Breakdown

Do not rotate or show in mirror-image form.

Style 1 

Add:

8.3.1A Bidirectional breakdown effect

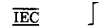







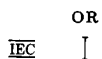



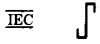
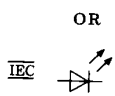
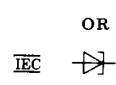
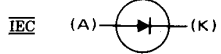
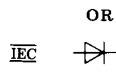



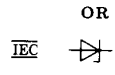



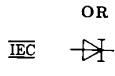

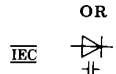
8.3.3 Backward

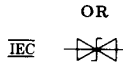
Style 1 

Add:

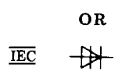
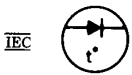
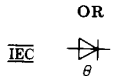
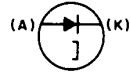

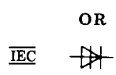
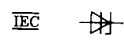
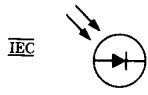
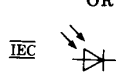
**Graphic Symbols for
Semiconductor Devices**

<p><i>After 8.3.4</i> <i>Add:</i> 8.3.5 Schottky effect</p> 	<p><i>Add:</i></p> 	<p><i>Add:</i></p> 
<p>8.5.1 Semiconductor diode; semiconductor rectifier diode; metallic rectifier</p>  <p><i>Add:</i></p> 	<p>8.5.6.1 Unidirectional diode; voltage regulator</p> <p>Style 1</p>  <p>OR</p>  <p>*Style 2</p>  <p><i>Add:</i></p> <p>*Note conflict with 8.3.1A</p> 	<p>8.5.7.2 Backward diode; tunnel rectifier</p> <p>For this application, NOTE 8.2.2A does not apply.</p> <p>Style 1</p>  <p>OR</p>  <p>Style 2</p>  <p><i>Add:</i></p> 
<p>8.5.2 Capacitive diode (varactor)</p> <p>Style 1</p>  <p><i>Add:</i></p> 	<p>8.5.6.2 Bidirectional diode</p> <p>Style 1</p>  <p>Style 2</p>  <p><i>Add:</i></p> 	<p>8.5.8 Thyristor, reverse-blocking diode-type</p> <p>8.5.8.1 General</p> <p>Style 1</p>  <p>OR</p>  <p>Style 3</p>  <p><i>Add:</i></p> 
<p>8.5.3 Temperature-dependent diode</p>  <p><i>Add:</i></p> 	<p>8.5.7 Tunnel and backward diodes</p> <p>8.5.7.1 Tunnel diode</p> <p>For this application, NOTE 8.2.2A does not apply.</p> <p>Style 1</p>  <p>OR</p>  <p>Style 2</p> 	<p><i>Add:</i></p>  <p><i>After 8.5.8.2</i> <i>Add:</i></p> <p>8.5.8.3 Reverse conducting diode thyristor</p> 
<p>8.5.4.1 Photosensitive type</p>  <p><i>Add:</i></p> 		
<p>8.5.4.2 Photoemissive type</p> <p>See also item 11.1.1</p> 		

8.5.9 Thyristor, bidirectional diode type; bi-switch
See also symbol 8.6.15

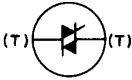

Add:

OR



Add:

8.5.11 Current regulator

*  (A) — (K)

*Note conflict with 8.3.3

8.6 Typical Applications, Three- (or more) Terminal Devices

8.6.1 PNP transistor (also PNIP transistor, if omitting the intrinsic region will not result in ambiguity)

NOTE 8.6.1A: See ANSI/IEEE Std 315-1975 [7], paragraph A4.11 of the Introduction.

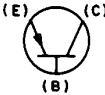

Add:

OR

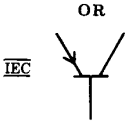

8.6.2 NPN transistor (also NPIN transistor, if omitting the intrinsic region will not result in ambiguity)

See NOTE 8.6.1A

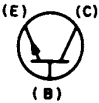

Add:

8.6.2A NPN transistor with collector connected to the envelope



After 8.6.2.1
Add:

8.6.2.2 NPN avalanche transistor

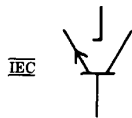

8.6.3 NPN transistor with transverse-biased base

See NOTE 8.6.1A



Add:

OR



8.6.4 PNIP transistor with ohmic connection to the intrinsic region

See NOTE 8.6.1A

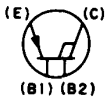

Add:

OR

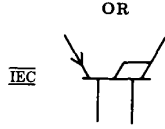

8.6.6 PNIN transistor with ohmic connection to the intrinsic region

See NOTE 8.6.1A

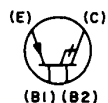

Add:

OR

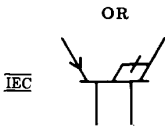

8.6.8 Unijunction transistor with N-type base

See NOTE 8.6.1A



Add:

OR



8.6.9 Unijunction transistor with P-type base

See NOTE 8.6.1A



Add:

OR

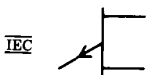

8.6.10 Field-effect transistor with N-channel (junction gate and insulated gate)

8.6.10.1 N-channel junction gate

If desired, the junction-gate symbol element may be drawn opposite the preferred source.

See NOTE 8.6.1A

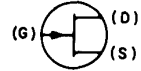

OR



Add:

OR

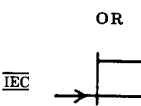

NOTE 8.6.10.1A: The gate and source connections shall be drawn in line.

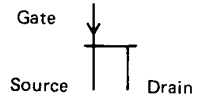

8.6.10.2 N-channel insulated-gate, depletion-type, single-gate, passive-bulk (substrate), three-terminal device

Add:

OR

8.6.10.2A IGFET enhancement-type, single-gate, N-type channel without substrate connection

8.3.10.3 N-channel insulated-gate, depletion-type, single-gate, active-bulk (substrate) internally terminated to source, three-terminal device

Add:

8.6.10.3A IGFET enhancement-type, single-gate, N-type channel with substrate internally connected to source

8.6.10.4 N-channel insulated-gate, depletion-type, single-gate, active-bulk (substrate) externally terminated, four-terminal device

8.6.10.4.1 Application: N-channel insulated-gate, depletion-type, two-gate, five-terminal device

Add:

OR

8.6.11 Field-effect transistor with P-channel (junction gate and insulated gate)

8.6.11.1 P-channel junction gate

See NOTE 8.6.1A

OR

Add:

OR

8.6.11.2 P-channel insulated-gate, depletion-type, single-gate, passive-bulk (substrate), three-terminal device

Add:

OR

8.6.11.2A Insulated-gate field-effect transistor (abridged IGFET) enhancement type, single gate. P-type channel without substrate connection

NOTE 8.6.11.2A: For an example with multiple gates, see symbol 8.6.10.4.1.

8.6.11.5 P-channel insulated-gate, enhancement-type, single-gate, active-bulk (substrate) externally terminated, four-terminal device

Add:

OR

8.6.12.1 General

Style 1

Style 3

Add:

OR

8.6.12.2 Gate turn-off type

Style 3

Add:

OR

8.6.13.1 General

Style 1

Style 3

Add:

OR

8.6.13.2 Gate turn-off type

Style 3

Add:

OR

8.6.14 Thyristor, reverse-blocking tetrode-type; semiconductor controlled switch

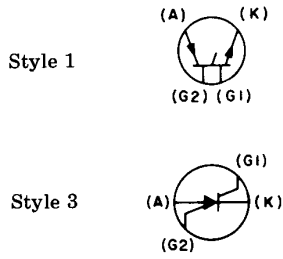

Add:

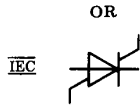

8.6.15 Thyristor, bidirectional triode-type; triac; gated switch

See also symbol 8.5.9

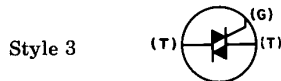

Add:

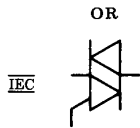

8.6.16 Phototransistor (PNP-type)

See also symbol 8.5.10, for 2-terminal device

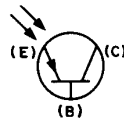

Add:

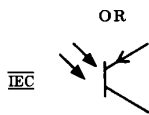

After 8.10.4

Add:

8.10.5 Optical coupling device

Opto isolator
Shown with light emitting diode and phototransistor

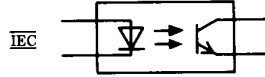

8.10.6 Magnetic coupling device

Magnetic isolator

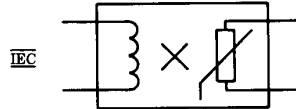

After 8.11.2

Add:

8.12 Ionizing Radiation Detectors

8.12.1 Detector, semiconductor type

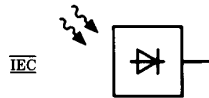

8.12.2 Scintillator detector

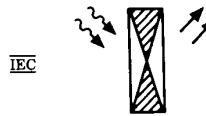

8.12.3 Cerenkov detector

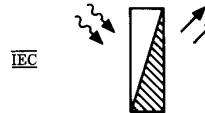

8.12.4 Thermoluminescence detector

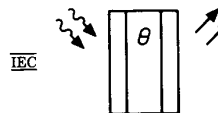

9.1 Fuse (one-time thermal current-overload device)

9.1.1 General

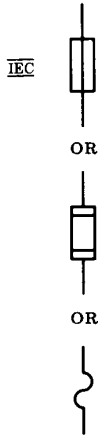

Add:

9.1.1A Fuse with mechanical linkage (striker fuse)

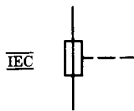

Revise:

9.1.2 Fuse with alarm contact

NOTE 9.1.2A: When fuse blows, alarm bus A is connected to power supply bus S. The letters S (supply), L (load), and A (alarm circuit) are for explanation only, and are not part of the symbol.

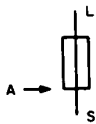

See NOTE 9.1.2A

Add:

9.1.2.1 Fuse with alarm contact, three terminals

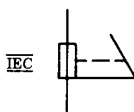

9.1.2.2 Fuse with separate alarm circuit

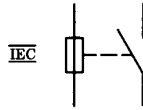

Add:

9.1.3.1 Fuse-switch

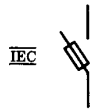

9.3 Lightning Arrester \overline{F} Arrester (electric surge, etc) Gap

See also symbol 8.5.6

9.3.1 General



Add:

OR



9.3.1.1 Double spark-gap

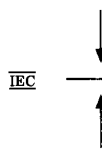

After 9.3.9

Add:

9.3.10 Surge arrester (Lightning arrester)

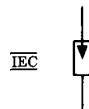

9.3.11 Protective gas discharge tube

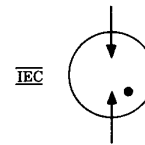

9.3.12 Symmetric protective gas discharge tube

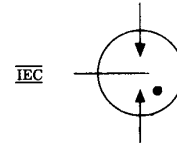

Revise 9.4 to read as follows:

9.4 Circuit Breaker \overline{F}

If it is desired to show the condition causing the breaker to trip, the relay protective-function symbols in item 9.5.1 may be used alongside the breaker symbol.

9.4.1 General



9.4.2 Air circuit breaker, if distinction is needed; for alternating-current circuit breakers rated at 1500 volts or less and for all direct-current circuit breakers.



9.4.3 Network protector



9.4.4 Circuit breaker, other than covered by symbol 9.4.1

The symbol in the right column is for a 3-pole breaker.

NOTE 9.4.4A: On a power diagram, the symbol may be used without other identification. On a composite drawing where confusion with the general circuit element symbol (item 16.1) may result, add the identifying letters CB inside or adjacent to the square.



See NOTE 9.4.4A

9.4.5 Application: 3-pole circuit breaker with thermal-overload device in all 3 poles

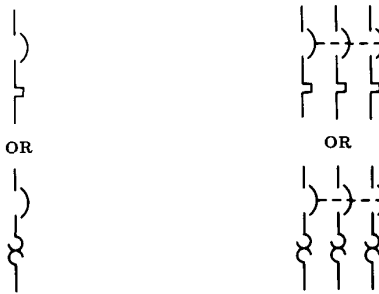

9.4.6 Application: 3-pole circuit breaker with magnetic-overload device in all 3 poles



9.4.7 Application: 3-pole circuit breaker, drawout type



After 9.5.12.20
Add:

9.6 Protective Relays (IEC Publication 617-7 (1983 [18]) Block Symbol and Qualifying Symbol

9.6.1 Measuring relay or related device

The asterisk must be replaced by one or more letters or qualifying symbols indicating the parameters of the device, in the following order; characteristic quantity and its mode of variation; direction of energy flow; setting range; resetting ratio; delayed action; value of time delay

NOTE 9.6.1A: Letter symbols for characteristic quantities should be in accordance with established standards, for example ISO 31, 0-11 (1974-1980) [25], IEC Publication 27 [9], ANSI/IEEE Std 260-1978 [5], and ANSI/IEEE Std 280-1985 [6].

Symbols 9.6.2, 9.6.4, and 9.6.7 show how letter and qualifying symbols may be combined.

NOTE 9.6.1B: A figure giving the number of similar measuring elements may be included in the symbol as shown in example 9.7.5.

NOTE 9.6.1C: The symbol may be used as a functional symbol representing the whole of the device, or as a symbol representing only the actuating element of the device.



9.6.2 Voltage failure to frame (frame potential in case of fault)

NOTE 9.6.2A: U may be replaced by V.

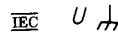

9.6.3 Residual voltage

The NOTE with symbol 9.6.2 is applicable

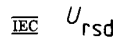

9.6.4 Reverse current

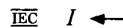

9.6.5 Differential current



9.6.6 Percentage differential current

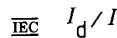

9.6.7 Earth fault current

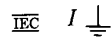

9.6.8 Current in the neutral conductor



9.6.9 Current between neutrals of two polyphase systems

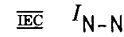

9.6.10 Power at phase angle alpha

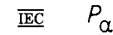

9.6.11 Inverse time-lag characteristic

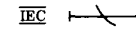

9.7 Examples of Protective Relays (IEC Publication 617-7 (1983) [18])

9.7.1 No voltage relay

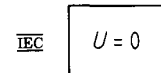

9.7.2 Reverse current relay

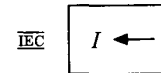

9.7.3 Underpower relay

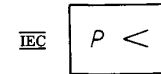

9.7.4 Delayed overcurrent relay

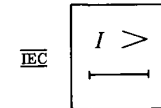

9.7.5 Overcurrent relay with two current elements and a setting range from 5 A to 10 A

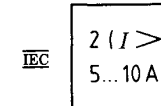

9.7.6 Maximum reactive power relay:

- Energy-flow towards the busbars
- Operating value 1 Mvar
- Time-lag adjustable from 5 s to 10 s

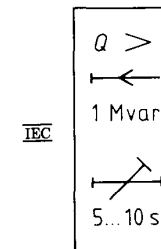

9.7.7 Undervoltage relay:

- Setting range from 50 V to 80 V
- Resetting ratio 130%

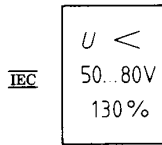

9.7.8 Current relay operating above 5 A and below 3 A

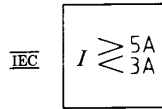

9.7.9 Under-impedance relay

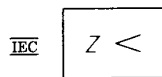

9.7.10 Relay detecting interturn short-circuits

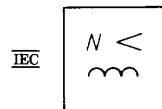

9.7.11 Divided-conductor detection relay

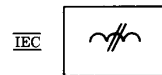

9.7.12 Phase-failure detection relay in a three-phase system

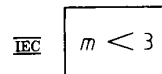

9.7.13 Locked-rotor detection relay operating by current sensing

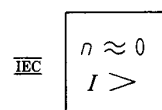

9.7.14 Overcurrent relay with two outputs, one active at current above five times the setting value, the other with inverse time-lag characteristic

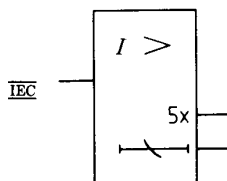

9.8 Other Relay Devices

9.8.1 Buchholz protective device (gas relay)

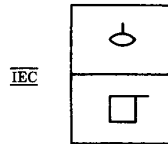

9.8.2 Auto-reclose device

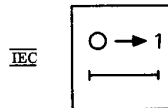

Section 10

Graphic Symbols for Acoustic Devices

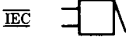
10.1.2 Buzzer  

Add:

OR



OR

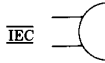

See NOTE 10.1.1A

Revise:

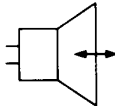
10.1.3.3 Loudspeaker-microphone 
Underwater sound transducer, two-way

After 10.1.4

Add:

10.1.5 Hydrophone (supersonic transmitter-receiver)

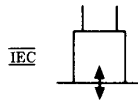

10.1.6 Horn

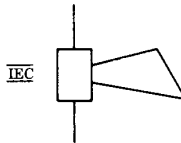

10.1.7 Siren

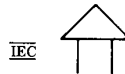

10.1.8 Whistle, electrically operated

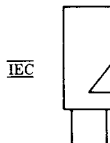

Section 11

Graphic Symbols for Lamps and Visual-Signaling Devices

After NOTE 11.1.1C
Add:

11.1.1A Lamp (IEC Publication 617-8 (1983) [19])

11.1.1A.1 Lamp, general symbol
Signal lamp, general symbol

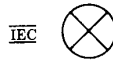

If it is desired to indicate the color, a notation according to the following code is placed adjacent to the symbol:

- RD = red
- YE = yellow
- GN = green
- BU = blue
- WH = white

If it is desired to indicate the type of lamp, a notation according to the following code is placed adjacent to the symbol:

- Nc = neon
- Xe = xenon
- Na = sodium vapor
- Hg = mercury
- I = iodine
- IN = incandescent
- EL = electroluminescent
- ARC = arc
- FL = fluorescent
- IR = infrared
- UV = ultraviolet
- LED = light-emitting diode

11.1.1A.2 Signal lamp, flashing type

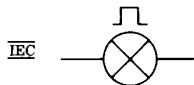

After 11.2.8
Add:

11.3 Electromechanical Signal

11.3.1 Indicator, electromechanical
Annunciator, element



11.3.2 Electromechanical position indicator with one de-energized (shown) and two operated positions

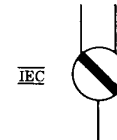

11.3.3 Coil operated flag indicator

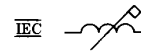

(Relocated from 6.2.9)

12.1 Meter Instrument

Add:

Note that IEC Publication 617-8 (1983) [19]

- Distinguishes symbolwise between indicating, recording, and integrating instruments (see 12.3)
- Carefully follows the lettering style (uppercase, lowercase) specified for the SI system of measurement (see 12.4 through 12.6)

NOTE 12.1A: The asterisk is not part of the symbol. Always replace the asterisk by one of the following letter combinations, depending on the function of the meter or instrument, unless some other identification is provided in the circle and explained on the diagram.



See NOTE 12.1A

12.1.1 Galvanometer $\overline{\text{E}}$

Avoid conflict with symbols 4.5 and 13.1.2 if used on the same diagram.

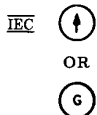

12.2 Electromagnetically Operated Counter Message Register
See also 12.7

12.2.1 General

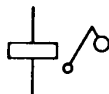

12.2.2 With make contact

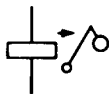

Add:

12.3 Indicating, Recording and Integrating Instruments, General Symbols (IEC Publication 617-8 (1983) [19])

NOTE 12.3A: The asterisk within the symbols of this section shall be replaced with one of the following:

- The letter symbol for the *unit* of the quantity measured, or a multiple or sub-multiple thereof (see examples 12.4.1 and 12.4.7)
- The letter symbol for the *quantity* measured (see examples 12.4.5 and 12.4.6)
- A chemical formula (see example 12.4.13)
- A graphic symbol (see example 12.4.8)

The symbol or formula used should be related to the information displayed by the instrument regardless of the means used to obtain the information.

NOTE 12.3B: Letter symbols for *units* and for *quantities* shall be selected from one of the parts of IEC Publication 27 [9], ANSI/IEEE Std 260-1978 [5], and ANSI/IEEE Std 280-1985 [6].

Provided IEC Publication 27 [9], ANSI/IEEE Std 260-1978 [5], ANSI/IEEE Std 280-1985 [6], or the letter symbols for chemical elements, do not apply, other letter symbols may be used, if they are explained on the diagram or in referenced documents.

NOTE 12.3C: If the letter symbol for the *unit* of the quantity measured is used, it may be necessary to show the letter symbol for the *quantity* as supplementary information. It should be placed below the unit letter symbol (see example 12.4.2).

Supplementary information concerning the quantity measured, and any necessary qualifying symbol may be shown below the quantity letter symbol.

NOTE 12.3D: If more than one quantity is indicated or recorded by an instrument, the appropriate symbol outlines shall be placed attached in line, horizontally or vertically (see examples 12.5.2 and 12.6.14).

12.3.1 Indicating instrument

The asterisk shall be replaced in accordance with the rules given in NOTE 12.3A

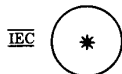

12.3.2 Recording instrument

The asterisk shall be replaced in accordance with the rules given in NOTE 12.3A

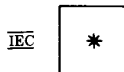

12.3.3 Integrating instrument Energy meter

The asterisk shall be replaced in accordance with the rules given in NOTE 12.3A

NOTE 12.3.3A: The symbol may also be used for a remote instrument which repeats a reading transmitted from an integrating meter. For example, see symbol 12.6.11.

NOTE 12.3.3B: The outline may be combined with that for a recording instrument to represent a combined instrument. For example, see symbol 12.6.14.

NOTE 12.3.3C: Symbols from 1.7 may be used to specify the direction of energy flow. For examples, see symbols 12.6.4 to 12.6.7.

NOTE 12.3.3D: The number of rectangles at the top of the symbol indicates the number of different summations by a multirate meter. For example, see symbol 12.4.8.

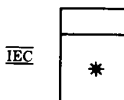

12.4 Examples of Indicating Instruments (IEC Publication 617-8 (1983) [19])

12.4.1 Voltmeter

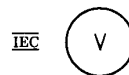

12.4.2 Reactive current ammeter

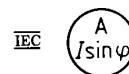

12.4.3 Maximum demand indicator actuated by an integrating meter

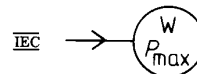

12.4.4 Varmeter

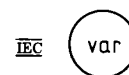

12.4.5 Power-factor meter



12.4.6 Phase meter



12.4.7 Frequency meter



12.4.8 Synchronoscope



12.4.9 Wavemeter



12.4.10 Oscilloscope



12.4.11 Differential voltmeter



12.4.12 Galvanometer



Graphic Symbols for
Readout Devices

12.4.13 Salinity meter

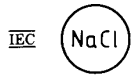

12.4.14 Thermometer
Pyrometer

NOTE 12.4.14A: θ may be replaced by t° .

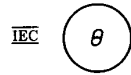

12.4.15 Tachometer

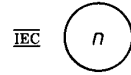

12.5 Examples of Recording Instruments (IEC Publication 617-8 (1983) [19])

12.5.1 Recording wattmeter

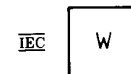

12.5.2 Combined recording wattmeter and varmeter

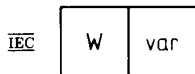

12.5.3 Oscillograph

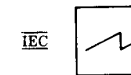

12.6 Examples of Integrating Instruments (IEC Publication 617-8 (1983) [19])

12.6.1 Hour meter

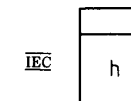

12.6.2 Ampere-hour meter

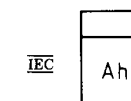

12.6.3 Watthour meter

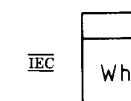

12.6.4 Watthour meter, measuring energy transmitted in one direction only

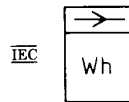

12.6.5 Watthour meter, measuring the energy flow from the busbars

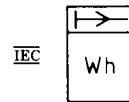

12.6.6 Watthour meter, measuring the energy flow towards the busbars

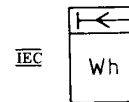

12.6.7 Import-export watthour meter

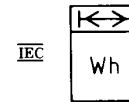

12.6.8 Multirate watthour meter, two-rate shown

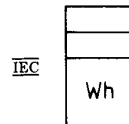

12.6.9 Excess watthour meter

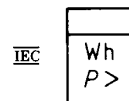

12.6.10 Watthour meter with transmitter

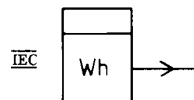

12.6.11 Remote meter (repeater) actuated by a watthour meter

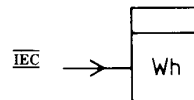

12.6.12 Remote meter (repeater) with printing device, actuated by a watthour meter

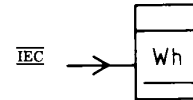

12.6.13 Watthour meter with maximum demand indicator

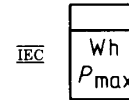

12.6.14 Watthour meter with maximum demand recorder

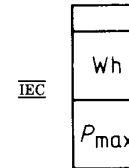

12.6.15 Varhour meter

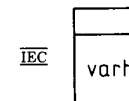

12.7 Counting Devices (IEC Publication 617-8 (1983) [19])

12.7.1 Counting function of a number of events, qualifying symbol

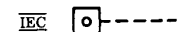

12.7.2 Pulse meter (electrically-operated counting device)

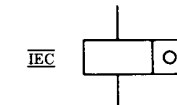

12.7.3 Pulse meter manually preset to n (reset if $n = 0$)

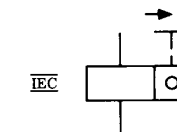

12.7.4 Pulse meter electrically reset to 0

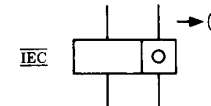

12.7.5 Pulse meter with multiple contacts
Respective contacts close once at every unit (10^0), ten (10^1), hundred (10^2), thousand (10^3) events registered by the counter

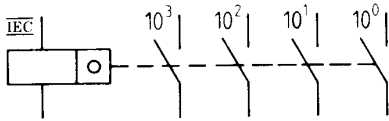

12.7.6 Counting device, cam driven and closing a contact for each n events

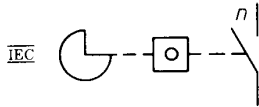

12.8 Telemetering Devices

12.8.1 Signal translator, general symbol

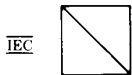

12.8.2 Telemetering transmitter

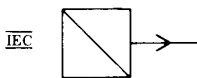

12.8.3 Telemetering receiver

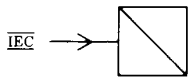

12.9 Electric Clocks

12.9.1 Clock, general symbol
Secondary clock



12.9.2 Master clock

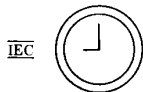

12.9.3 Clock with switch

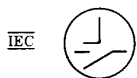

Section 13

Graphic Symbols for
Rotating Machinery

Add:

13.1.5A Brush (on slip-ring or commutator)

NOTE 13.1.5A: Brushes are shown only if necessary.

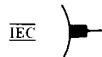

13.5.1.4 Linear induction motor, three-phase, movement limited to one direction

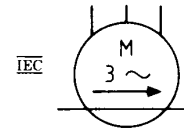

Add:

13.1.7 Linear motor, general symbol

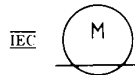

13.1.8 Stepping motor, general symbol

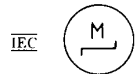

Add:

13.6.1.1 Synchronous generator, three-phase, permanent magnet

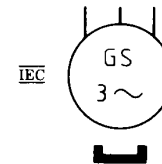

Add:

13.5.1.1 Induction motor, three-phase, squirrel cage

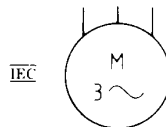

13.5.1.2 Induction motor, single-phase, squirrel cage, leads of split phase brought out

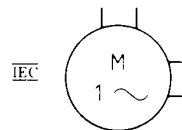

13.5.1.3 Induction motor, three-phase, star-connected, with automatic starter in the rotor

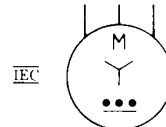

14.2 Mechanical Motion
14.2.1 Translation, one direction



Add:

14.2.1A Rectilinear force or motion in the direction of the arrow

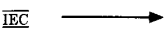

14.2.2 Translation, both directions



Add:

14.2.2A Bidirectional rectilinear forces or motion

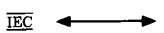

EXAMPLE: Frequency is increased when wiper 3 is moved towards terminal 2

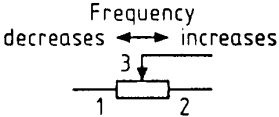

After 14.2.4

Add:

14.2.4A Bidirectional rotation, limited in both directions



14.2.4.1 Alternating or reciprocating
For application see symbol 2.3.7.7

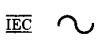

Add:

OR

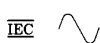

After 14.2.6

Add:

14.2.7 Delayed action
14.2.7.1 Delayed action

NOTE 14.2.7.1A: Delayed action in the direction of movement from the arc towards its center.

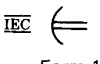

Form 1

14.2.7.2

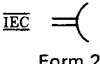

Form 2

Revise 14.3.3 to read as follows:

14.3.3 Brake applied when operating means (not shown) is energized

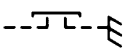

OR

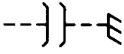

Revise 14.3.4 to read as follows:

14.3.4 Brake released when operating means (not shown) is energized

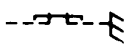

OR

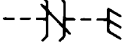

Add:

14.3.5 Brake (IEC Publication 617 (1983) [13])



14.3.5.1 EXAMPLE: Electric motor with brake applied.

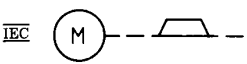

14.3.5.2 EXAMPLE: Electric motor with brake released.

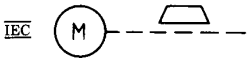

14.3.6 Gearing

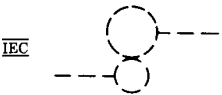

After 14.4.2

Add:

14.4.2A Operating by pulling.

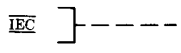

Add:

14.4.4 Manually operated control with restricted access

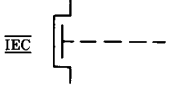

14.4.5 Operated by turning

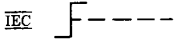

14.4.6 Operated by proximity effect



14.4.7 Operated by touching



14.4.8 Emergency switch (mushroom-head safety feature)

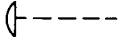

14.4.9 Operated by handwheel



14.4.10 Operated by pedal

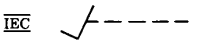

14.4.11 Operated by lever

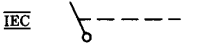

14.4.12 Operated by removable handle

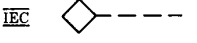

14.4.13 Operated by key

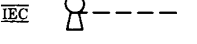

14.4.14 Operated by crank

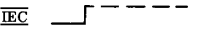

14.4.15 Operated by roller

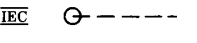

14.4.16 Operated by cam

NOTE 14.4.16A: If desired, a more detailed drawing of the cam may be shown. This applies also to a profile plate.

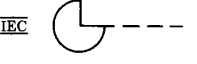

14.4.16.1 EXAMPLE: Cam profile

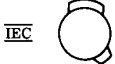

14.4.16.2 Profile plate
Cam profile (developed representation)

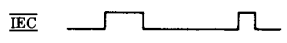

**Graphic Symbols for
Mechanical Functions**

14.4.16.3 Operated by cam and roller



14.4.17 Operated by stored mechanical energy

NOTE 14.4.17A: Information showing the form of stored energy may be added in the square.



14.4.18 Operated by pneumatic or hydraulic control, single acting



14.4.19 Operated by pneumatic or hydraulic control, double acting

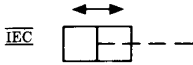

14.4.20 Operated by electromagnetic actuator

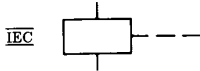

14.4.21 Operated by electromagnetic overcurrent protection

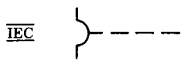

14.4.22 Operated by thermal actuator, for example thermal relay, thermal overcurrent protection

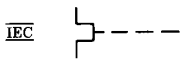

14.4.23 Operated by electric motor

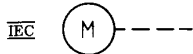

14.4.24 Operated by electric clock

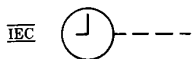

14.5 Detents, Latching, and Blocking

14.5.1 Automatic return

NOTE 14.5.1A: The triangle is pointed in the return direction.



14.5.2 Detent
Nonautomatic return
Device for maintaining a given position

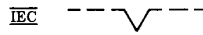

14.5.3 Detent, disengaged

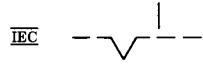

14.5.4 Detent, engaged

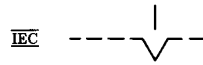

14.5.5 Mechanical interlock between two devices

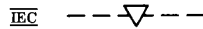

14.5.6 Latching device, disengaged

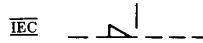

14.5.7 Latching device, engaged

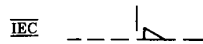

14.5.8 Blocking device



14.5.9 Blocking device engaged, movement to the left is blocked



15.2 Coupling

Commonly used in coaxial and waveguide diagrams.

Add:

15.2A Coupler (or feed) type unspecified, general symbol



15.2A.1 EXAMPLE: Coupler to a cavity resonator

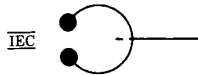

15.2A.2 EXAMPLE: Coupler to a rectangular waveguide

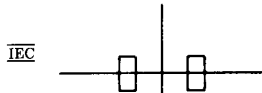

After 15.2.7

Add:

15.2.8 Slow-wave coupler

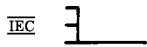

15.2.9 Helical coupler

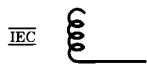

After 15.4.4.2

Add:

15.4.4.3 Quadrature hybrid junction

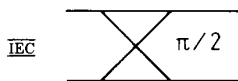

After 15.5.3

Add:

15.5.4 Taper transition from circular to rectangular waveguide

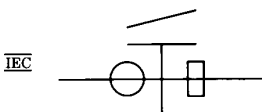

15.6 Mode Suppressor

Commonly used in coaxial and waveguide transmission.

15.6.1 General

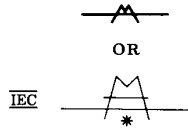

The asterisk shall be replaced by the indication of the mode suppressed

15.7 Rotary Joint (radio-frequency rotary coupler [F])

Add:

15.7A Rotatable joint, with symmetrical connectors

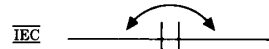

15.8.4.1 Reversible direction

Current entering the coil at the end marked with the dot causes the energy in the circulator to flow in the direction of the arrowhead marked with the dot.

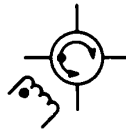

Add:

OR

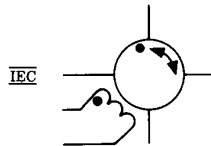

Add:

15.9.1.1 Cavity resonator forming an integral part of tube

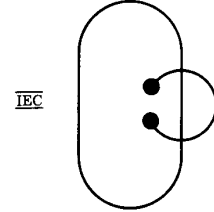

15.9.1.2 Cavity resonator, partly or wholly external to tube

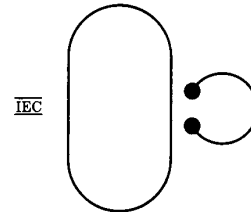

After 15.9.4

Add:

15.9.5 Tetrapole

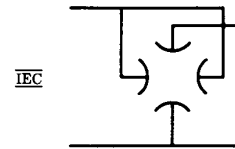

15.9.5.1 Tetrapole with loop coupler

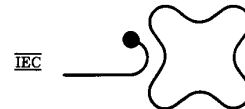

After 5.10.3

Add:

15.10.4 Permanent magnet producing a transverse field (in a crossed field or magnetron type tube)

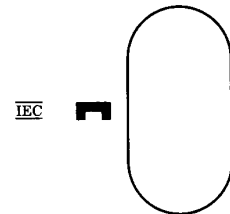

15.10.5 Electromagnet producing a transverse field (in a crossed field or magnetron type tube)

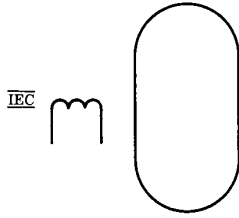

15.11 Magnetron

15.11.1 Resonant type with coaxial output

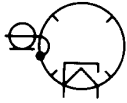

Add:

15.11.1A Magnetron oscillator tube with:

- Indirectly heated cathode
- Closed slow-wave structure with dc connection by way of a waveguide
- Permanent field magnet
- Window-coupler to rectangular waveguide

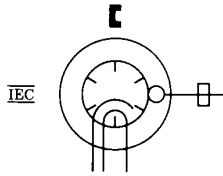

15.11.1A.1



Simplified form

After 15.11.3

Add:

15.11.4 Backward (traveling) wave oscillator tube (voltage tunable magnetron) with:

- Indirectly heated cathode
- Intensity modulating electrode
- Beam-forming plate
- Closed slow-wave structure with dc connection by way of waveguide
- Nonemitting sole
- Permanent field magnet
- Window-coupler to rectangular waveguide

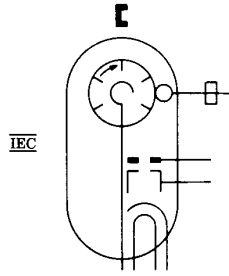

15.11.4.1



Simplified form

After 15.12.1

Add:

- 15.12.1A Reflex klystron with:
- Indirectly heated cathode
 - Beam-forming plate
 - Grid
 - Tunable integral cavity resonator
 - Reflector
 - Loop coupler to coaxial output

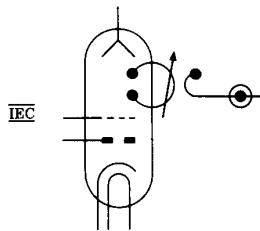

15.12.1A.1

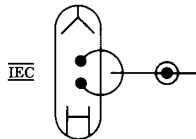

Simplified form

After 15.12.2

Add:

15.12.3 Klystron with:

- Indirectly heated cathode
- Intensity modulating electrode
- Beam-forming plate
- External tunable input cavity resonator
- Drift space electrode
- External tunable output cavity resonator with dc connection
- Collector
- Focusing coil
- Input loop coupler to coaxial waveguide
- Output window coupler to rectangular waveguide

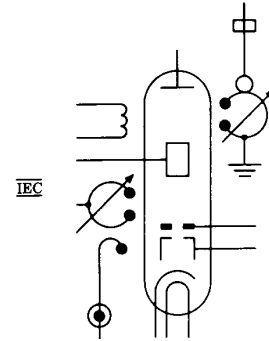

15.12.3.1

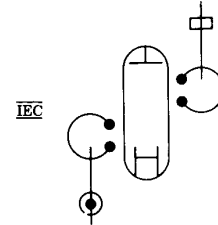

Simplified form

After 15.13

Add:

15.13.1 T-R tube

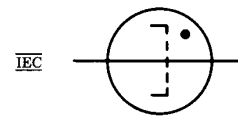

After 15.14.8

Add:

15.14.9 O-type forward traveling wave amplifier tube with:

- Indirectly heated cathode
- Intensity modulating electrode
- Beam-forming plate
- Slow-wave structure with dc connection
- Collector
- Focusing coil
- Probe-couplers to rectangular waveguides each with sliding short

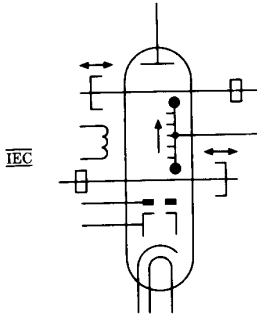

For a simplified form see symbol 15.14.11.1.

15.14.10 O-type forward traveling wave amplifier tube with:

- Indirectly heated cathode
- Intensity modulating electrode
- Beam-forming plate
- Slow-wave structure with dc connection
- Collector
- Permanent focusing-magnet
- Slow-wave couplers to rectangular waveguides

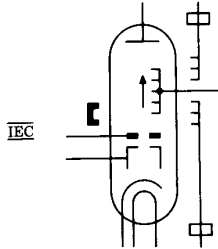

For a simplified form see symbol 15.14.11.1.

15.14.11 O-type forward traveling wave amplifier tube with:

- Indirectly heated cathode
- Intensity modulation electrode
- Beam-forming plate
- Slow-wave structure with dc connection
- Electrostatic focusing electrode
- Collector
- Slow-wave couplers to rectangular waveguides

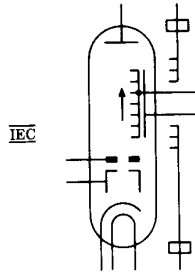

For a simplified form see symbol 15.14.11.1.

15.14.11.1 O-type forward traveling wave amplifier tube, simplified representation (simplified form for symbols 15.14.9, 15.14.10, and 15.14.11)

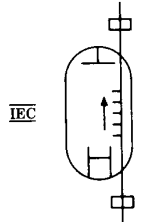

Simplified Form

15.14.12 M-type forward traveling wave amplifier tube with:

- Indirectly heated cathode
- Intensity modulating electrode
- Beam-forming plate
- Preheated nonemitting sole
- Slow-wave structure with dc connection
- Collector
- Permanent transverse field magnet
- Window couplers to rectangular waveguides

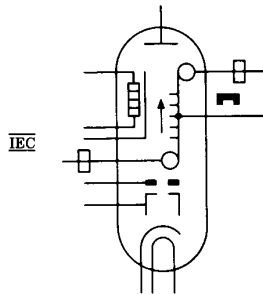

15.14.12.1

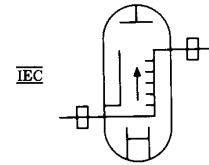

Simplified form

15.14.13 M-type backward (traveling) wave amplifier tube with:

- Filament-heated emitting sole
- Slow-wave structure with dc connection
- Permanent transverse field magnet
- Window-couplers to rectangular waveguides

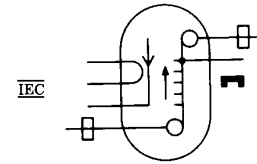

15.14.13.1

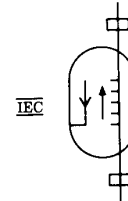

Simplified form

15.14.14 M-type backward (traveling) wave oscillator tube with:

- Indirectly heated cathode
- Intensity modulating electrode
- Beam-forming plate
- Nonemitting sole
- Slow-wave structure with dc connection by way of waveguide
- Collector
- Permanent transverse field magnet
- Window-coupler to rectangular waveguide

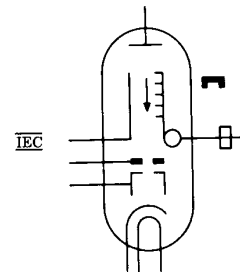

15.14.14.1

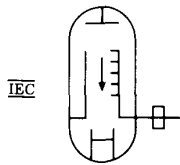

Simplified form

15.16 Filter

15.16.1 Mode filter

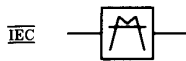

Add:

OR



The asterisk shall be replaced by the indication of the mode suppressed.

After 15.16.2

Add:

15.16.3 Bandpass filter switched by gas discharge

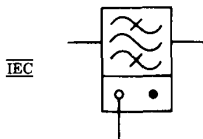

After 15.19

Add:

15.20 Multiport Devices

15.20.1 Three-port junction

NOTE 15.20.1A: The type of coupling, power division proportions, reflection coefficients, etc. may be indicated as shown below. The angles between the ports may be drawn as convenient.



15.20.1.1 EXAMPLE: Series T, E-plane T



15.20.1.2 EXAMPLE: Shunt T, H-plane T



15.20.1.3 EXAMPLE: Power divider:
Power divided into ratio
6:4

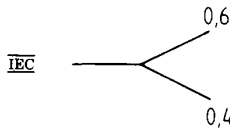

15.20.2 Four-port junction

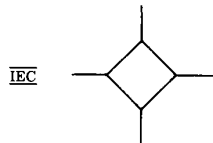

Form 1

15.20.2.1

NOTE 15.20.2.1A: The convention is that the power entering at one port is conveyed only to the two directly connected ports and thence away from the device.

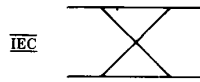

Form 2

15.21 Lasers and Masers

15.21.1 Maser, general symbol

NOTE 15.21.1A: The symbol \bar{I} represents the transition from one energy level to a lower one. It is drawn preferably in the lower left-hand quarter of the square.

NOTE 15.21.1B: Pumping by light may be shown by placing symbol 1.3.1 (\searrow) above

- (a) An appropriate symbol chosen from 1.4, or
- (b) The chemical symbol for the material

For example of application, see symbol 15.21.2.2

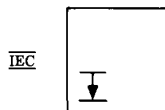

15.21.1.1 EXAMPLE: Maser used as an amplifier

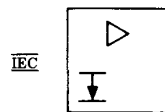

15.21.2 Laser (optical maser), general symbol

The NOTES with symbol 15.21.1 apply.

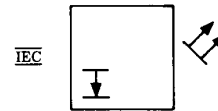

15.21.2.1 EXAMPLES: Laser used as a generator

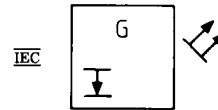

15.21.2.2 Ruby laser generator

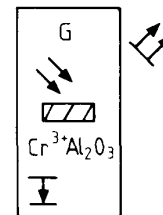

15.21.2.3 Ruby laser generator, shown with xenon lamp as pumping source

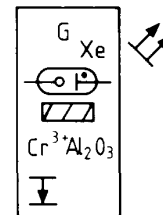

After 16.1.1

Add:

16.1.1A Item
Equipment
Functional unit

NOTE 16.1.1A: Suitable symbols or legends shall be inserted in or added to the symbol outline to indicate the item, equipment, or function.

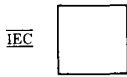

Form 1

OR



Form 2

OR

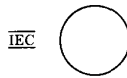

Form 3

Revise 16.1.1.1 to read as follows:

16.1.1.1 Accepted abbreviations from ANSI Y1.1-1972 (R 1984) [1] may be used in the rectangle.

After 16.2.8

Add:

16.2.9 Negative impedance both-way amplifier

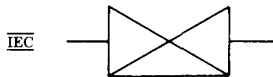

16.2.10 Amplifier with bypass used for signaling or power feeding, or both

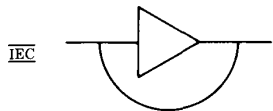

16.2.11 Amplifier with external direct-current control

NOTE 16.2.11A: The controlled quantity may be indicated beside the arrowhead.

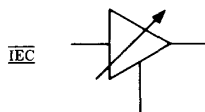

Revise 16.9 to read as follows:

16.9 Gyro
Gyroscope
Gyrocompass



Add:

16.9.1 Gyro

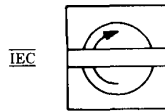

Add:

16.13 Changer, General Symbol
Converter, General Symbol

If the direction of change is not obvious, it may be indicated by an arrowhead on the outline of the symbol.

A symbol or legend indicating the input or output quantity, waveform, etc may be inserted in each half of the general symbol to show the nature of the change.

See IEC Publication 617-6 (1983) [17], Production and Conversion of Electrical Energy, and IEC Publication 617-10 (1983) [21], Telecommunications: Transmission.

The diagonal line from this symbol is used in the form of a solidus to show a converting function.

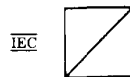

16.13.1 DC converter

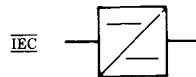

16.13.2 Rectifier

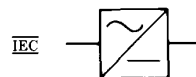

16.13.3 Rectifier in full wave (bridge) connection

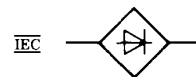

16.13.4 Inverter

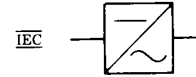

16.13.5 Rectifier/inverter

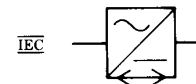

16.14 Galvanic Separator

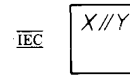

NOTE 16.14A: If necessary, indication of the way of separation may be given below the qualifying symbol.

For example: X//Y
↓ ↓

Galvanic separation by opto-coupler

16.15 Heat Source, General Symbol



16.15.1 Radioisotope heat source



16.15.2 Combustion heat source



16.16 Generator, General Symbol



NOTE 16.16A: For a rotating generator, use symbol See 13.1

16.16.1 Thermoelectric generator, with combustion heat source

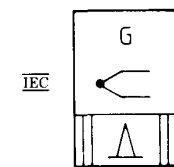

16.16.2 Thermoelectric generator with nonionizing radiation heat source

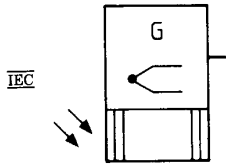

16.16.3 Thermoelectric generator with radioisotope heat source

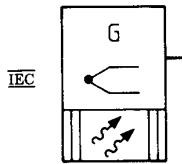

16.16.4 Thermionic diode generator with nonionizing radiation heat source

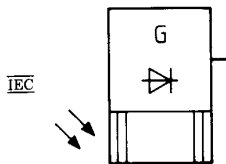

16.16.5 Thermionic diode generator with radioisotope heat source

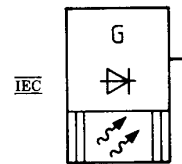

16.16.6 Photovoltaic generator

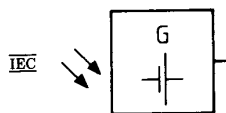

16.17 Sensors and Detectors
16.17.1 Proximity sensor

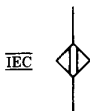

16.17.2 Proximity sensing device, block symbol

NOTE 16.17.2A: The method of operating may be indicated.

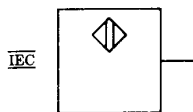

16.17.2.1 EXAMPLE: Capacitive proximity detector operating on the approach of solid material

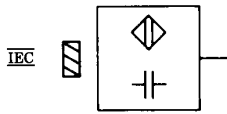

16.17.3 Touch sensor

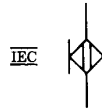

16.18 Applications of Sensors

16.18.1 Touch sensitive switch, make contact

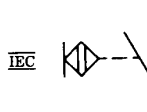

16.18.2 Proximity switch, make contact

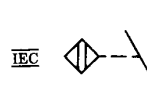

16.18.3 Proximity switch, operated on the approach of a magnet, make contact

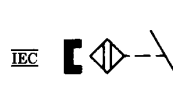

16.18.4 Proximity switch, operated on the approach of iron, break contact

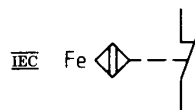

NOTE 17A: The existing Section 17, symbols 17.1 through 17.9 (inclusive) filled a need for programming operations using general purpose computers equipped with removable programming (patch) panels. IEC Publication 617-13 (1978) [24] provides a more sophisticated system.

17.10 Analog Elements
(IEC Publication 617-13 (1978) [24])
for Computation and Control

17.10.1 General Rules

(1) In many figures lowercase letters appear that are not part of the symbols and are added only for the purpose of identification of inputs and outputs as referenced in the description.

(2) The symbols for sign indication are + and -. They are placed inside the outline of the symbol adjacent to each relevant input and output.

(3) Weighting factors applied to the input signals are each indicated by a sign indicator in combination with a numerical value placed inside the outline of the symbol adjacent to the relevant input.

In this standard w_1, w_2, \dots, w_n which are understood to include the proper sign, will be used to denote the values of the weighting factors. When the weighting factor is +1 or -1, the number 1 may be omitted.

(4) The symbol f is used to denote the function of an analog element. f may be replaced by a symbol or a graph denoting the actual function.

(5) EXAMPLE:

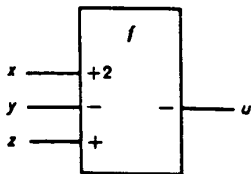

Element in which:

$$u = -f(2x, -y, z)$$

17.10.2 Qualifying symbols for signal identification

See 1.15

17.10.3 Qualifying symbols for amplifiers

(1) When an element performs a specific function in addition to amplification, f may be replaced by the appropriate qualifying symbol (see symbols 17.10.3.1 to 17.10.3.4) or may be omitted if no confusion can arise.

(2) In particular cases, for example integrating amplifiers, special purpose inputs may be defined using symbols 17.10.3.5 to 17.10.3.11. If these symbols are not sufficient, controlling inputs should be labelled C_1, C_2, \dots etc, and the effects of these should be defined in an associated table.

17.10.3.1 Summing

$$\overline{\text{IEC}} \sum$$

17.10.3.2 Integrating

$$\overline{\text{IEC}} \int$$

17.10.3.3 Differentiating

$$\overline{\text{IEC}} \frac{d}{dt}$$

17.10.3.4 Logarithmic

$$\overline{\text{IEC}} \log$$

17.10.3.5 Frequency compensation

$$\overline{\text{IEC}} F$$

17.10.3.6 Initial condition, analog value of integration

$$\overline{\text{IEC}} I$$

17.10.3.7 Control: the defined 1-state allows integration

$$\overline{\text{IEC}} C$$

17.10.3.8 Hold: the defined 1-state holds last value

$$\overline{\text{IEC}} H$$

17.10.3.9 Reset: the defined 1-state resets the output condition to zero

$$\overline{\text{IEC}} R$$

17.10.3.10 Set: the defined 1-state sets to initial condition

$$\overline{\text{IEC}} S$$

17.10.3.11 Supply voltage (to be used if special requirements exist). Any necessary identification of the supply (numeric) or polarity (+ or -) follows the letter U

$$\overline{\text{IEC}} U$$

17.10.4 Amplifiers

17.10.4.1 Amplifier for analog computation. General symbol.

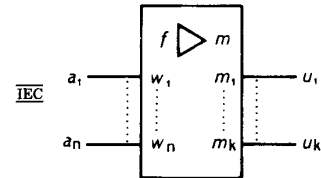

$w_1 \dots w_n$ represent the signed values of the weighting factors.

$m_1 \dots m_k$ represent the signed values of the amplification factors.

$$u_i = m_i \cdot m_1 \cdot f(w_1 \cdot a_1, w_2 \cdot a_2, \dots, w_n \cdot a_n)$$

where:

$$i = 1, 2, \dots, k$$

The sign of the amplification factor is to be maintained at each of the outputs, except for those being digital in nature.

When there is only one amplification factor for the whole element, or there is a common factor resulting from weighting factors and amplification factors, the m in the qualifying symbol may be replaced by the absolute value.

When $m = 1$, the number 1 may be omitted. Signs should always be maintained at analog outputs.

The use of the sign ∞ as an amplification factor is recommended where the nominal open loop gain is very high and the knowledge of its exact value is not of particular concern.

EXAMPLES:

17.10.4.2 High gain differential amplifier (operational amplifier)

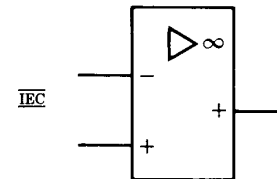

17.10.4.3 High gain amplifier with a nominal amplification of 10 000 and two complementary outputs

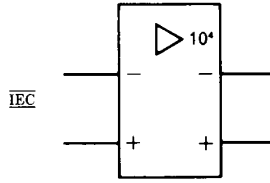

17.10.4.4 Inverting amplifier with an amplification of 1

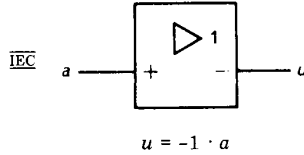

17.10.4.5 Amplifier with two outputs, the upper, noninverting, has an amplification of 2, the lower, inverting output, has an amplification of 3

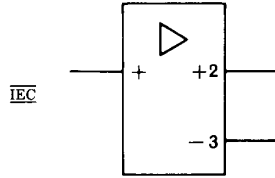

17.10.4.6

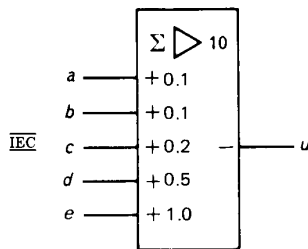

Summing amplifier

$$u = -10 (0.1a + 0.1b + 0.2c + 0.5d + 1.0e) \\ = -(a + b + 2c + 5d + 10e)$$

17.10.4.7 Integrating amplifier (integrator)

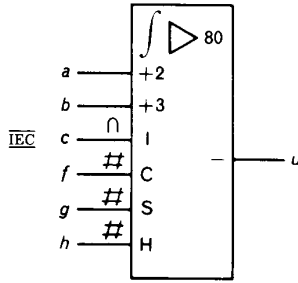

If $f = 1$, $g = 0$, and $h = 0$, then

$$u = -80 \left[c_{(t=0)} + \int_0^t (2a + 3b) dt \right]$$

NOTE: The symbols for signal identification (\cap and $\#$) may be omitted if no ambiguity arises.

17.10.4.8 Differentiating amplifier (differentiator)

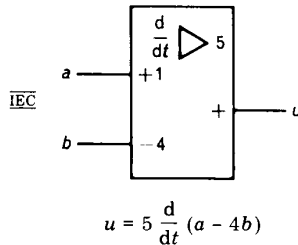

17.10.4.9 Logarithmic amplifier

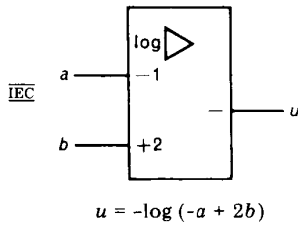

17.10.5 Function generators
17.10.5.1 Function generator, general symbol

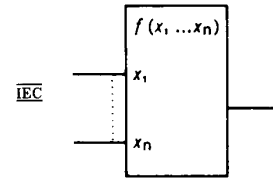

$x_1 \dots x_n$ represent the arguments of the function and may each be replaced by an appropriate indication, provided that no ambiguity can arise. All weighting factors are assigned the value +1 and are therefore omitted.

$f(x_1 \dots x_n)$ shall be replaced by an appropriate indication of, or reference to, the function (see for example, IEC Publication 27-1 (1971) [9]).

NOTE 17.10.5.1A: the graphic “/” shall not be used for the indication of the division because of ambiguity with the symbols for the level converter and the code converter.

EXAMPLES:

17.10.5.2 Multiplier with weighting factor of -2

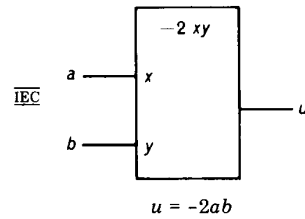

17.10.5.3 Divider

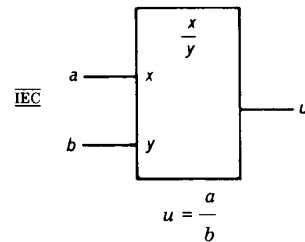

17.10.5.4 Multiplier-divider

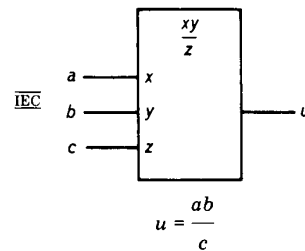

17.10.5.5 Cotangent function

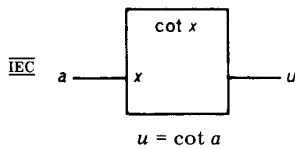

17.10.5.6 Exponential function

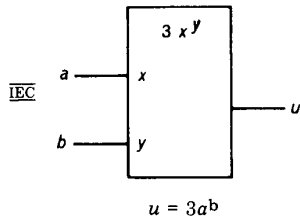

17.10.6 Coordinate converters

17.10.6.1 Coordinate converter, polar to rectangular

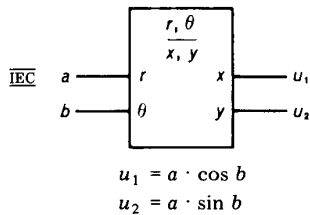

17.10.6.2 Coordinate converter, rectangular to polar

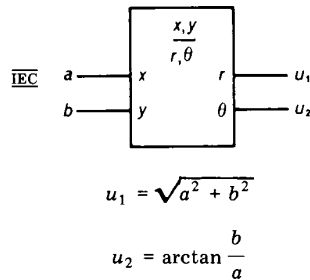

17.10.7 Signal converters

(1) The indication of the specific relation between inputs and outputs may be shown inside the outline.

(2) If the digital information is serial, the most significant bit is presented first unless otherwise indicated.

17.10.7.1 Digital to analog converter. General symbol.

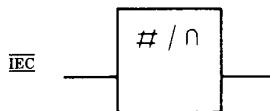

17.10.7.2 Analog to digital converter. General symbol.

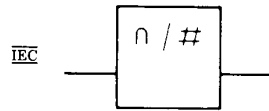

17.10.7.3 Analog to digital converter that converts the input range 4 mA-20 mA into a 4-bit weighted binary code.

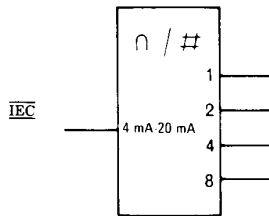

17.10.8 Electronic switches

NOTE: Electronic switches are being considered in connection with binary logic elements. The results of this work may be published as a supplement to IEC Publication 617-12 (1983) [23]. See ANSI/IEEE Std 91-1984 [4].

17.10.8.1 Bidirectional switch (make), general symbol

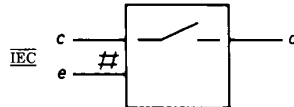

The analog signal can pass in either direction between *c* and *d* as long as the digital input *e* stands at its defined 1-state.

NOTE 17.10.8.1A: An arrow may be added to indicate an unidirectional switch (make).

17.10.8.2 EXAMPLE: The analog signal can pass only in the direction indicated by the arrow as long as the digital input *e* stands at its defined 1-state.

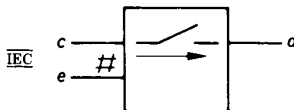

17.10.8.3 Bidirectional switch (break), general symbol

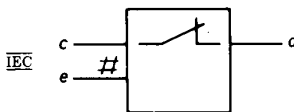

The analog signal can pass in either direction between *c* and *d* as long as the digital input *e* stands at its defined 0-state.

NOTE 17.10.8.3A: An arrow may be added to indicate an unidirectional switch (break).

17.10.8.4 EXAMPLE: The analog signal can pass only in the direction indicated by the arrow as long as the digital input *e* stands at its defined 0-state.

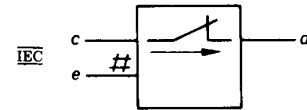

17.10.8.5 Bidirectional transfer switch operated by the AND function of two digital inputs.

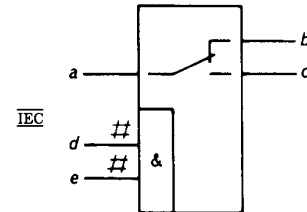

17.10.8.6 Two independent bidirectional switches (one make and one break), both operated by the same binary input.

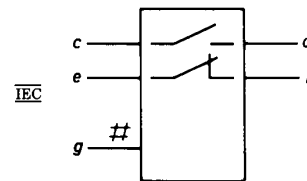

17.10.9 Coefficient scaler

NOTE 17.10.9A: The value of the coefficient may be shown adjacent to and outside the outline of the symbol.

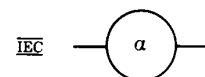

Section 20

Communications Equipment

Relocate:

20.3.2 Relocate to 24.2.1

20.3.3 Relocate to 24.2.2

21.1 Generating Station

NOTE 21.1A: Symbols for "planned" applications appear at the left; symbols for "in service" applications appear at the right.

NOTE 21.1B: The preferred symbol is the square, but if necessary, a rectangle may be used.

NOTE 21.1C: Relative sizes of symbols are shown. Symbol size may be reduced for small-size diagrams. See also paragraph A4.5 of the Introduction.

21.1.1 General
See NOTE 21.1A



Add:

21.1.2 Combined electric and heat generating station

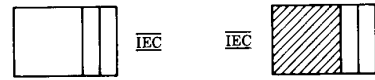

Revise to read as follows:

21.2 Hydroelectric Generating Station
See NOTE 21.1A

21.2.1 General



21.2.2 Run of river



21.2.3 With storage



21.2.4 With pumped storage



▲
PLANNED

▲
IN SERVICE

21.3 Thermoelectric Generating Station

See NOTE 21.1A

21.3.1 General



21.3.2 Coal or lignite fueled



21.3.3 Oil or gas fueled



21.3.4 Nuclear-energy fueled



21.3.5 Geothermic



Add:

21.3.6 Solar generating station



Revise to read as follows:

21.4 Prime Mover (qualifying symbols)

Use if essential to show the type of prime mover in a generating station.

See NOTE 21.1A

21.4.1 Gas turbine



21.4.1.1 Application: shown for oil- or gas-fueled generating station



21.4.2 Reciprocating engine



▲
PLANNED

▲
IN SERVICE

21.4.2.1 Application: shown for oil- or gas-fueled generation station



21.5 Substation

See NOTE 21.1A

21.5.1 General

Avoid conflict with symbol 13.1.1 if used on the same diagram.



21.5.2 Rectifier substation

Use if essential to show type of equipment.



Add:

21.5.3 Converting substation, dc to ac shown

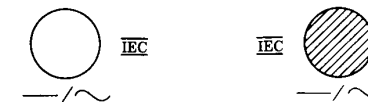

21.6 Wind Generating Station



**21.7 Plasma Generating Station
MHD (magneto-hydrodynamic)**



▲
PLANNED

▲
IN SERVICE

24.1 Switching Systems

The symbols in this section may be used to represent switching systems without regard to the type of equipment used as shown in the examples of trunking diagrams in the Appendix to this section.

The following terms are used in this section with the meaning as given below.

Connecting stage:

An arrangement of inlets and outlets so that only one switching point is used to connect one inlet to an outlet. A number of connections may exist at any time in one connecting stage.

Marking stage:

In a common-control system, that sequence of connecting stages that is controlled by one marking process. A marking stage may consist of one or more connecting stages.

Switching stage:

A sequence of connecting stages that jointly perform a specified switching function, for example preselection or route selection.

Highway-group:

The maximum number of circuits that have access to one highway.

24.1.1 Connecting stage

24.1.1.1 Connecting stage, shown with inlets and outlets, general symbol
Circuits on one side can be connected individually to circuits on the other side

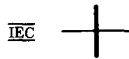

24.1.1.2 Connecting stage with x inlets and y outlets

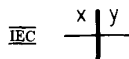

24.1.1.3 Connecting stage composed of z grading groups, each consisting of x inlets and y outlets

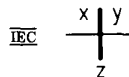

24.1.1.4 Connecting stage with one group of inlets and two groups of outlets

NOTE 24.1.1.4A: The number of inlets or outlets in each group may be indicated by a figure on the relevant line.

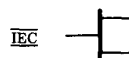

24.1.1.5 Connecting stage interconnecting one group of bothway trunks with two groups of unidirectional trunks of opposite sense

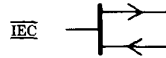

24.1.2 Marking stage

24.1.2.1 Marking stage consisting of only one connecting stage

NOTE 24.1.2.1A: The qualifying symbol indicating a marking stage is a dot. It should be added to the inlets of the first connecting stage and to the outlets of the last connecting stage of that marking stage.



24.1.2.2 EXAMPLES: Marking stage consisting of three connecting stages

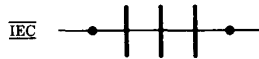

24.1.2.3 Mixed marking stage consisting of one, two, and three connecting stages

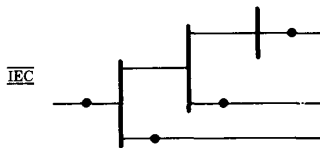

24.1.3 Switching stage

24.1.3.1 Switching stage consisting of one connecting stage

NOTE 24.1.3.1A: The qualifying symbol indicating a switching stage is an arc. It should be added to the inlets of the first connecting stage and to the outlets of the last connecting stage of that switching stage.

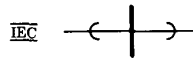

24.1.3.2 EXAMPLES: Switching stage consisting of three connecting stages



24.1.3.3 Mixed switching stage consisting of one, two, and three connecting stages

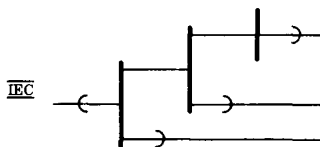

24.1.4 Examples of trunking diagrams

24.1.4.1 Trunking diagram for a switching system that consists of two marking stages, ABC or ABCD and E, EF or EFG, interconnected by other equipment represented by the squares. Calls are routed as follows:

- (1) Incoming calls by way of DCBA
- (2) Calls between subscribers connected to the same exchange by way of ABC, EF, and CBA
- (3) Outgoing calls by way of ABC and either E, EF, or EFG

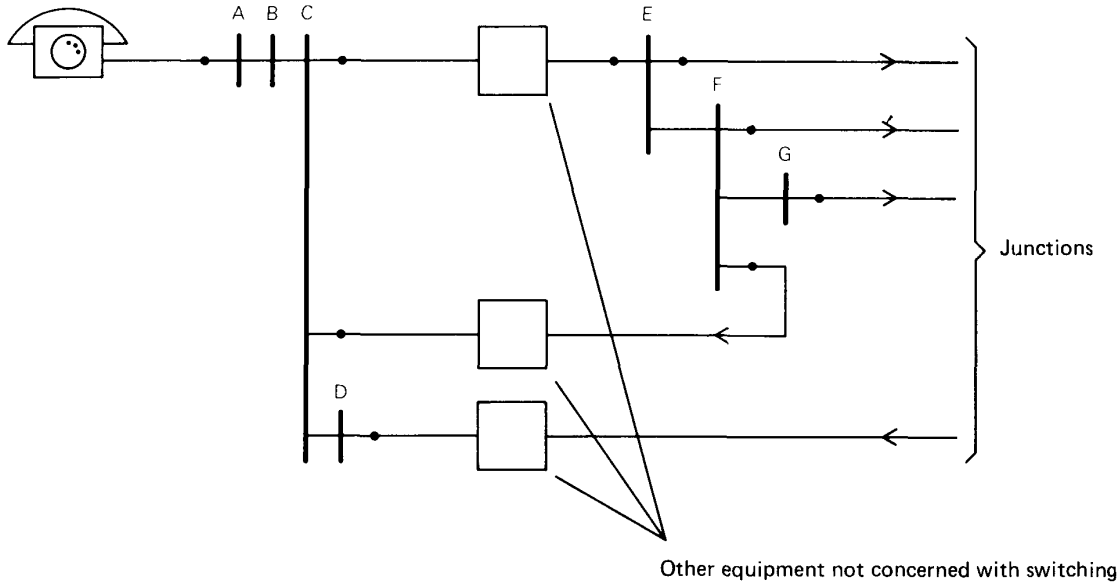

24.1.4.2 Trunking diagram of a switching system showing three switching stages

- (1) Preselection stage A
- (2) Route selection stage B or BC
- (3) Final selection stage D

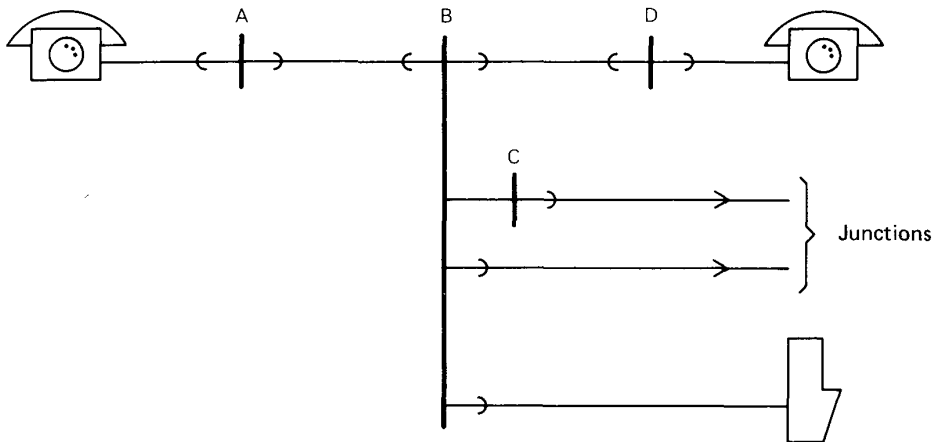

24.2 Block Symbols for Switching Equipment

24.2.1 Automatic switching*



*Relocated from 20.3.2

24.2.2 Manual switchboard*



*Relocated from 20.3.3

24.3 Qualifying Symbols for Transducers, Recorders, and Reproducers

24.3.1 Magnetic type



24.3.2 Moving coil or ribbon type



24.3.3 Moving iron type



24.3.4 Stereo type



24.3.5 Disc type



24.3.6 Tape or film type



24.3.7 Drum type



24.3.8 Recording or reproducing (the arrow points in the direction of energy transfer)



24.3.9 Recording and reproducing



24.3.10 Erasing



24.4 Recorders and Reproducers

24.4.1 Recorder or reproducer, or both, general symbol

NOTE 24.4.1A: The qualifying symbol depicting a transducer head may be replaced by other qualifying symbols.

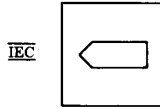

24.4.1.1 EXAMPLE: Recorder and reproducer, magnetic drum type

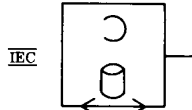

24.4.2 Reproducer with a stylus operated head

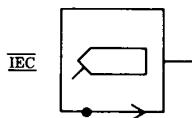

24.4.3 Recorder, film-type, with a head producing modulated light

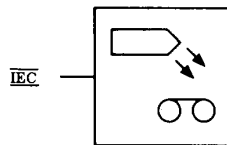

24.4.4 Reproducer, disc-type, with a light-operated head

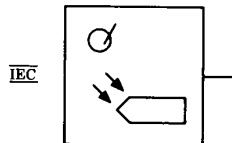

25.1 Amplified Circuits

25.1.1 Two-wire line with unidirectional amplification

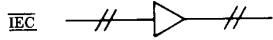

25.1.2 Two-wire line with both-way amplification



25.1.3 Four-wire circuit with both-way amplification



Form 1

OR

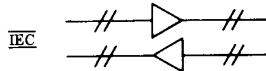

Form 2

25.1.4 Four-wire type circuit with frequency separation

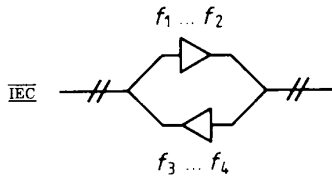

25.1.5 Four-wire circuit with both-way terminal amplification with echo suppression

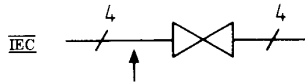

Form 1

OR

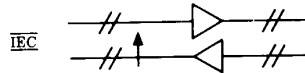

Form 2

25.2 Qualifying Symbols for Pulse Modulation

25.2.1 Pulse-position or pulse-phase modulation

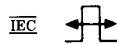

25.2.2 Pulse-frequency modulation



25.2.3 Pulse-amplitude modulation

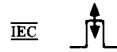

25.2.4 Pulse-interval modulation

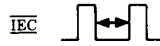

25.2.5 Pulse-duration modulation

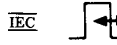

25.2.6 Pulse-code modulation

NOTE 25.2.6A: The * must be replaced by details of the code.



25.2.6.1 EXAMPLE: 3-out-of-7 code

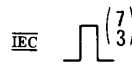

25.3 Signal Generator
Waveform Generator



25.3.1 Sine-wave generator, 500 Hz

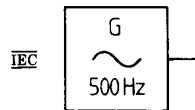

25.3.2 Sawtooth generator, 500 Hz

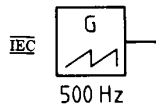

25.3.3 Pulse generator

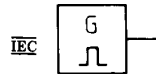

25.3.4 Variable frequency sine-wave generator

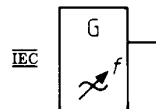

25.3.5 Noise generator

k = Boltzmann's constant
 T = absolute temperature

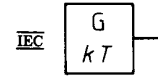

25.4 Changers
Converter, General Symbol

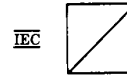

25.4.1 Frequency changer, changing from f_1 to f_2

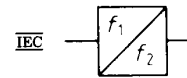

25.4.2 Frequency multiplier

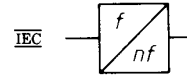

25.4.3 Frequency divider

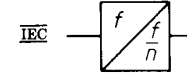

25.4.4 Pulse inverter

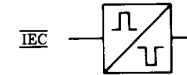

25.4.5 Code converter, five-unit binary code to seven-unit binary code

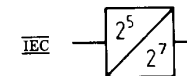

25.4.6 Changer giving clock-time indication in five-unit binary code

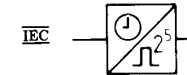

25.4.7 Pulse regenerator

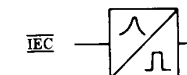

25.5 Filters

25.5.1 Filter, general symbol

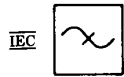

25.5.2 High-pass filter

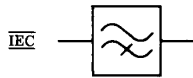

25.5.3 Low-pass filter

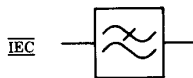

25.5.4 Band-pass filter

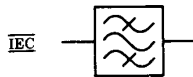

25.5.5 Band-stop filter

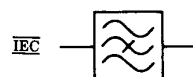

25.6 Networks

25.6.1 Device for pre-emphasis of higher frequencies

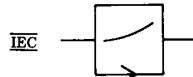

25.6.2 Device for de-emphasis of higher frequencies



25.6.3 Compressor

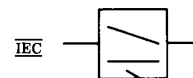

25.6.4 Expander

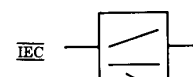

25.6.5 Artificial line

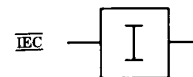

25.6.6 Phase-changing network

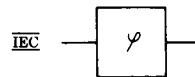

NOTE: φ may be replaced by B if no confusion arises

*Coordinate with symbol 15.17

25.6.7 Distortion corrector, general symbol

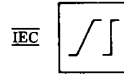

25.6.8 Amplitude/frequency distortion corrector, for example, equalizer

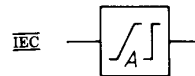

25.6.9 Phase/frequency distortion corrector

NOTE 25.6.9A: If it is desirable to indicate that the equalization refers to the time derivative of φ, φ may be replaced by Φ.

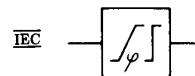

25.6.10 Delay/frequency distortion corrector

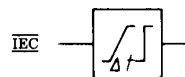

25.6.11 Nondistorting amplitude controller

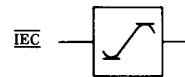

25.6.12 Mixing network

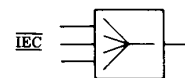

25.7 Electronic Chopping Device

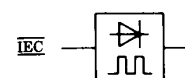

25.8 Threshold Devices

There are two ways of showing details of the operation carried out by a threshold device. The first is the use of the symbol 25.8.1 supplemented by appropriate waveform symbols on the input and output lines. The second is the use of a specific symbol consisting of a rectangle containing a figure derived from the input/output characteristic in the following manner:

The axes are deleted, but the origin is indicated by a short vertical stroke representing the y-axis

EXAMPLE:

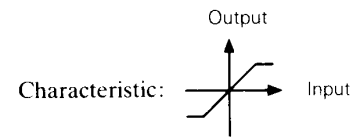

The origin may be located in the rectangle in such a position that the characteristic makes the maximum use of the available space

EXAMPLE:

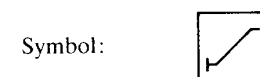
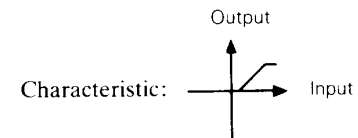

25.8.1 Threshold device, type unspecified (for example clipper)

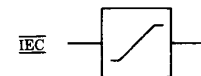

25.8.2 Device having a linear input/output characteristic for all signals that exceed a given threshold value and which has no output for input signals having an instantaneous amplitude between zero and that threshold

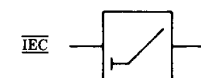

Telecommunications Transmission

25.8.3 Device having a linear input/output characteristic for all signals that exceed a preset threshold value and that has no output for input signals having an instantaneous amplitude between zero and that threshold

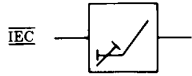

25.8.4 Positive peak clipper

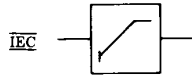

25.8.5 Negative peak clipper

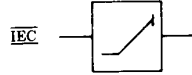

25.9 Terminating Sets

25.9.1 Terminating set

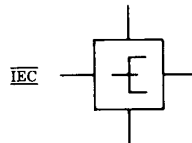

25.9.2 Balancing network

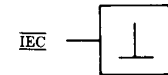

25.9.3 Terminating set with balancing network

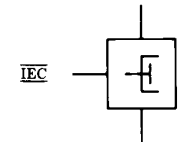

25.9.4 Hybrid transformer

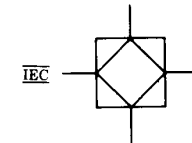

25.9.5 Asymmetric (skew) hybrid transformer, shown with balancing network

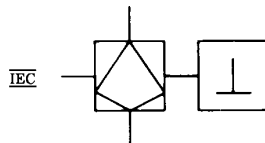

25.9.6 Equipment for connecting a four-wire circuit to either a two-wire circuit or a four-wire circuit depending upon the reception of a control signal

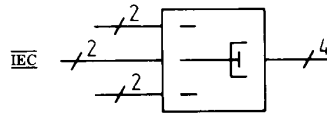

25.10 Modulator
Demodulator
Discriminator

25.10.1 General symbol

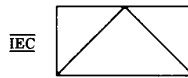

NOTE 25.10.1A: This symbol is used as follows: (Letters and input and output lines have been added in the figure for the purpose of explanation.)

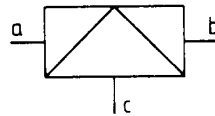

a and b represent the modulating or modulated signal input and the modulated or demodulated signal output

c represents the input of the carrier-wave if required

Qualifying symbols may be placed inside or outside the symbol as shown below

25.10.1.1 Modulator, double side-band output

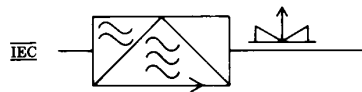

25.10.1.2 Pulse code modulator (seven-unit binary code output)

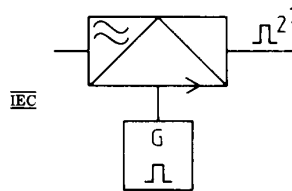

25.10.2 Demodulator, single side-band with suppressed carrier to audio

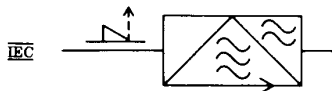

25.11 Concentrators
Multiplexers

25.11.1 Concentrating switching function from left to right, qualifying symbol



25.11.2 Expanding switching function from left to right, qualifying symbol



25.11.3 EXAMPLES: Concentrator with m input circuits and n output circuits

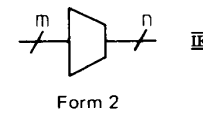
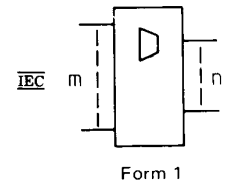

25.11.4 Multiplexing function, qualifying symbol

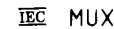

25.11.5 Demultiplexing function, qualifying symbol

NOTE 25.11.5A: If confusion can arise, DX may be replaced by DMUX.



25.11.6 Multiplexing and demultiplexing function, qualifying symbol



25.11.7 Multiplexer with analog/digital conversion

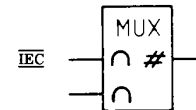

25.11.8 Multiplexer/demultiplexer with analog/digital conversion

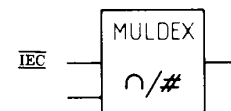

25.12 Frequency Spectrum Diagram Symbol Elements

A frequency spectrum is represented on a diagram by means of symbols on a horizontal frequency axis. The symbols show the functions of the various frequencies and frequency bands used in the transmission system as well as their relative positions in the spectrum.

25.12.1 Carrier frequency

NOTE 25.12.1A: When this symbol is used to represent a carrier that is modulated in frequency or phase the f or φ is added. See, for example, symbol 25.13.2.

NOTE 25.12.1B: The arrowhead on the vertical line representing the carrier (and the arrowhead on the frequency axis) may be omitted if no confusion will result.

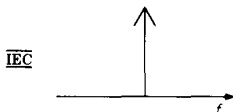

25.12.1.1 Suppressed-carrier frequency

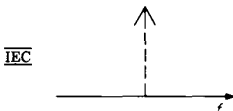

25.12.1.2 Reduced-carrier frequency

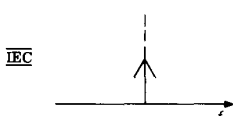

25.12.2 Pilot frequency

NOTE 25.12.2A: For FDM transmission systems the order of the group to which the pilot refers, that is, group, supergroup, mastergroup, or supermastergroup may be indicated by adding the respective number 1, 2, 3, or 4 of oblique strokes.

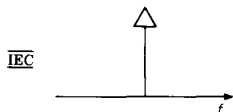

EXAMPLE: Supergroup pilot frequency

25.12.2.1

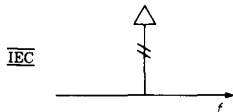

25.12.2.2 Suppressed pilot frequency

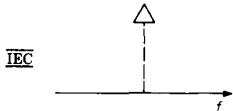

25.12.3 Additional measuring frequency

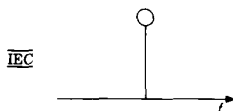

25.12.3.1 Additional measuring frequency, transmitted or measured on request



25.12.4 Signaling frequency

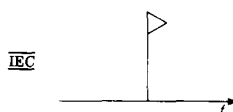

25.12.5 Frequency band

NOTE 25.12.5A: If it is desired to show whether a particular band of frequencies is erect or inverted, symbol 25.12.6 or 25.12.7 should be used.

NOTE 25.12.5B: The order of a band of frequencies forming part of a transmission system may be indicated by adding oblique strokes according to NOTE 25.12.2A of symbol 25.12.2.

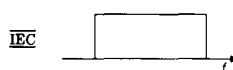

25.12.5.1 EXAMPLE: Mastergroup

NOTE 25.12.5.1A: The division of a band into channels, groups, etc. may be shown by adding vertical lines.

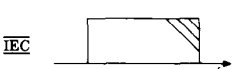

25.12.5.2 EXAMPLE: Band of frequencies from f_1 to f_2 divided into five channels, groups, etc.

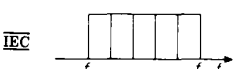

25.12.6 Erect band of frequencies

NOTE 25.12.6A: There is no indication of how much of the bandwidth shown by the symbol is actually used.

NOTE 25.12.6B: This symbol may be used to represent a single channel, group, etc. or a number of channels, groups, etc. providing they are all erect.

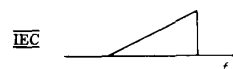

25.12.6.1 EXAMPLE: Band of frequencies consisting of a group of 12 erect channels



25.12.6.2

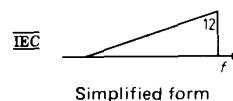

25.12.7 Inverted band of frequencies

NOTES 25.12.6A and 25.12.6B apply.

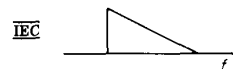

25.12.8 Band of mixed channels, groups, etc. some erect, remainder inverted

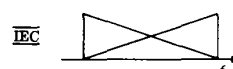

25.13 Examples of Frequency Spectrum Diagrams

25.13.1 Amplitude-modulated carrier with both sidebands

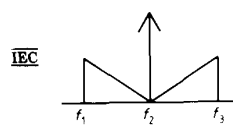

25.13.2 Phase modulated carrier with both sidebands

NOTE 25.13.2A: For frequency modulation, replace φ with f .

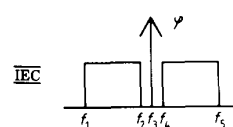

25.13.3 Amplitude-modulated carrier with both sidebands, lower modulating frequencies not being transmitted

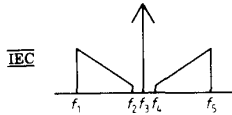

25.13.4 Amplitude-modulated carrier with both sidebands, modulating frequencies down to zero being transmitted

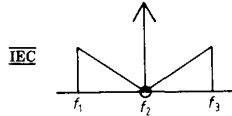

25.13.5 Single-sideband suppressed carrier

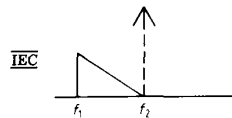

25.13.6 Reduced-carrier with single, lower, erect sideband

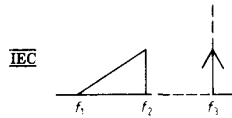

25.13.7 Suppressed-carrier with single-sideband scrambled for secrecy



25.13.8 Amplitude-modulated carrier with upper sideband and lower vestigial sideband, modulating frequencies down to zero being transmitted

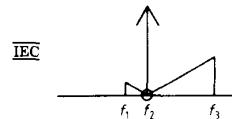

25.13.9 Band of five channels, groups, etc, four of which are inverted and one erect



Telecommunications Transmission

25.13.10 4 MHz transmission system showing supergroups and pilot frequencies

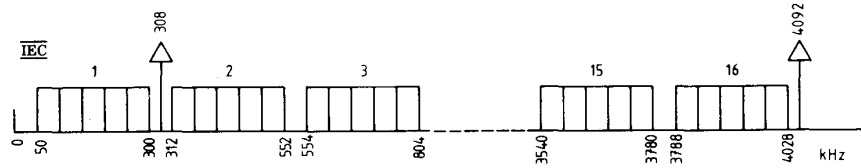

25.14 Fiber Optic Devices
25.14.1 Guided light transmitter

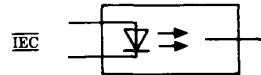

25.14.2 Guided light receiver

